

Project

Pre-test : multiple choice question paper for the pupils

Preliminaries

Read to your students the short text here after about Eratosthenes : it should sharpen their curiosity and then motivate them to join the project fully.

"In Egypt, about 2200 years ago, a papyrus drew attention of a certain Eratosthenes, then Director of the Great Library of Alexandria (a town located on the side of the Mediterranean Sea): it was about a vertical stick which, on the first day of summer (that is to say on June the 21st) and at noon local solar time, did not cast any shadow on the ground (the Sun's rays reach the bottom of a well!). This happened very far from Alexandria, straight to the South, in a town called Syene (now Aswan). However, Eratosthenes noticed from his side that in Alexandria, on June the 21st also and at the same time, a stick vertically driven in the ground did cast a shadow, even if such a shadow was relatively short.

What the hell was this mystery?

We invite you to discover it by yourselves. This will lead you pretty far since, as Eratosthenes showed, the key of this mystery will allow you to measure the circumference of the Earth, nothing less!"

You should subsequently see, in sessions 4 and 5, how to fill in this tale and which simulations to suggest your pupils. The same way, bibliographic researches will be carried out later on. But your students will of course be able to comment this true story, and start locating the two cities involved.

Then, tell them to make them feel better about the multiple choice question paper :

"During the numerous activities we will carry out about this project "Following the footsteps of Eratosthenes", we will tackle with a series of fascinating subjects about which you might already have ideas about. But keep in mind that if you can't answer some of the questions, or if you make mistakes in your answers, it is not important at all : the questionnaire will not be graded for it is rather a test game. However, don't hesitate to ask precisions about a question if you don't understand the meaning of it and to simply answer "I don't know" if it is the case."

Practical methods

Foreseen duration : according to the training of your pupils, one session of 45 minutes, or two sessions of about 30 minutes (but the slowest students will have to be able to finish later)



Equipment :

For each student :

the sheets of the multiple choice question paper
and a few blank sheets for the required
drawings in several questions ;
a black pencil, an eraser, a color pencil case or
felt-tip pens.

PROJECT : “FOLLOWING THE FOOTSTEPS OF ERATOSTHENES ”

15 questions to take stock of your knowledge on several topics

Before answering a question, first read it to the end.

*When you have to pick a proposed answer, **circle** the one you pick with your black pencil.*

*When you have to answer with a **drawing**, make it on a separate piece of paper and write first the number of the question on the sheet.*

1 – Let's go in the shade !

Have you ever observed shadows? Try to draw the shadow of a stick in the sun (the stick is stuck in the ground).

Then do the same thing for three sticks well spread out.

2 – Is the blackboard askew ?

Vertical, horizontal : draw a picture to illustrate these two words. First draw a line to represent the ground; then, draw a vertical object as if it was put on it, and afterwards another one next to it, but horizontal.

Can you name (and draw?) two instruments to check :

- the verticality of the first object : _____

- the horizontality of the second object : _____

3 – At the angle of my street

Maybe you already know what an angle is, and perhaps also a straight angle? Among the following angles circle the one you reckon to be straight ones.

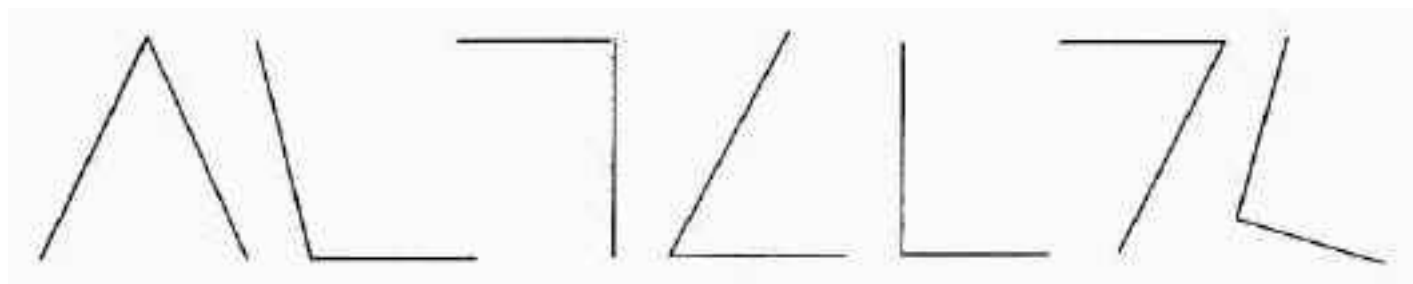

Do you know how to call an angle that is less open than a straight angle?

It is called a(n) _____ angle

Do you know the instruments used to measure the "spread" of an angle?

It is called a _____

4 – Let's take a street parallel to yours...

Have you ever heard of "parallel straight lines"? Even if you haven't, you might be able to find what it's about giving a look at the following group of straight lines :

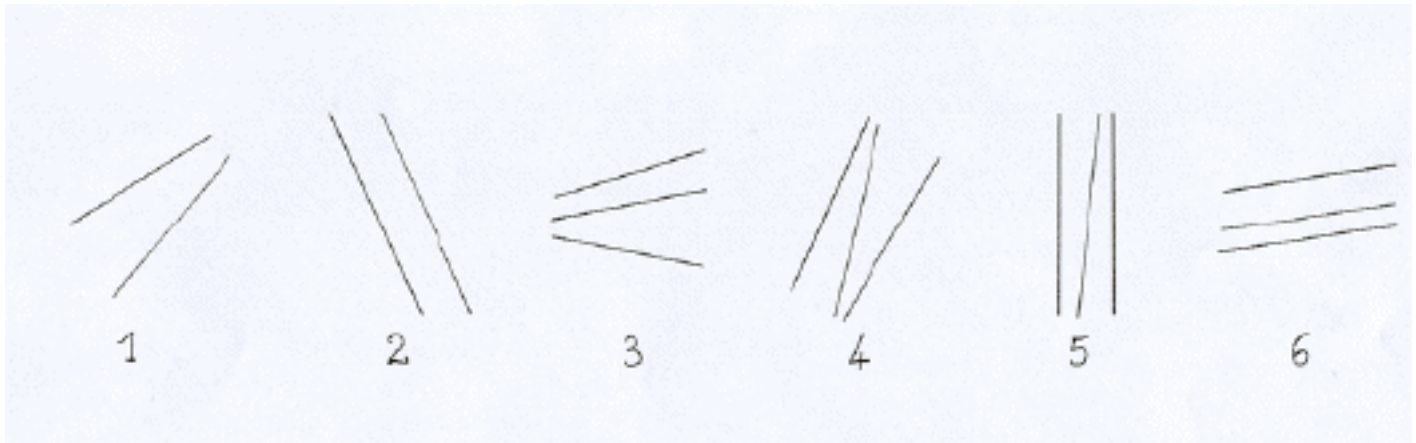

If you think you have found some, circle the group of parallel straight lines on the picture.

5 – Z as in Zorro (this question is reserved to junior high school students)

Look at the three steps of the construction of this funny "Z" :

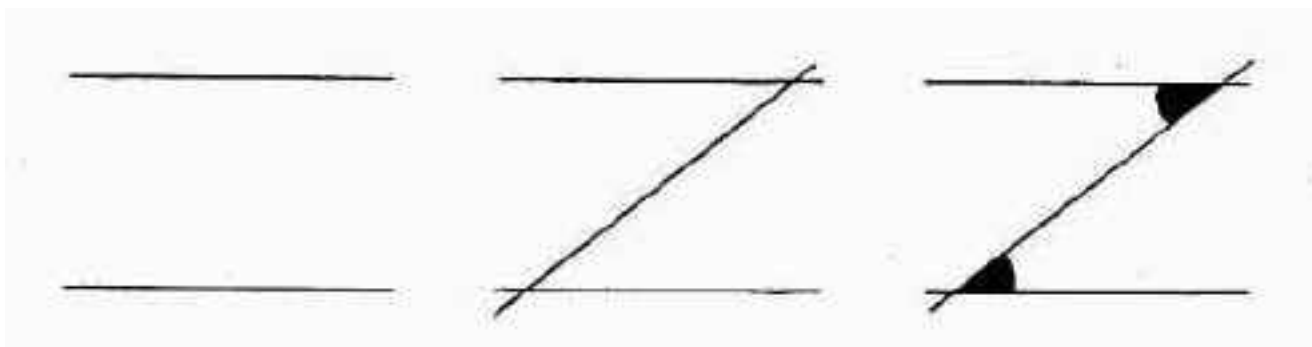

The two angles colored in black

have a particularity : which one ? _____

We could check it, how? _____

6 – Welcome to the Earth !

What is the shape of the Earth? (Draw it on a piece of paper)

How do you know ? _____

What object does it make you think of? _____

7 – Sticks again !

Take the picture of the Earth you just drew, and add, around it, three little sticks stuck in the ground like posts but very spread out.

8 – The Earth under the sun

Draw the Earth as you imagine it can be seen from space, with continents for instance, but also with the Sun illuminated it. If you want to show that it is the night somewhere on your planet, carefully color it in black.

9 – Day and night

Among the following 4 sentences, circle the one(s) that express(es) in a correct way, according to you, why it is alternately daytime and nighttime for the inhabitants of the Earth : (you can circle several answers)

- 1) The Earth revolves around the Sun
- 2) The Sun revolves around the Earth
- 3) The Earth revolves around itself
- 4) The Earth revolves around itself and around the Sun

10 – A little wind from the West

Here is a map of France with, on its side, what is called a compass card : it indicates the direction of the four cardinal points that are the following :

North (N) Sud (S) East (E) West (W)



Write down the initial letter (Capital letter) on the right spot at the tip of the arrows of the compass card. On the map, locate your school : pick a region more to the North of the location and write North, a region more to the South and write South, and so on...

11 – Travelling all over the vast world

Here is a map representing the five continents : it is called a planisphere. Write down the names of the four cardinal points in the small rectangles. Locate France, the United States, China, Lapland coloring them with a different color for each one of them.

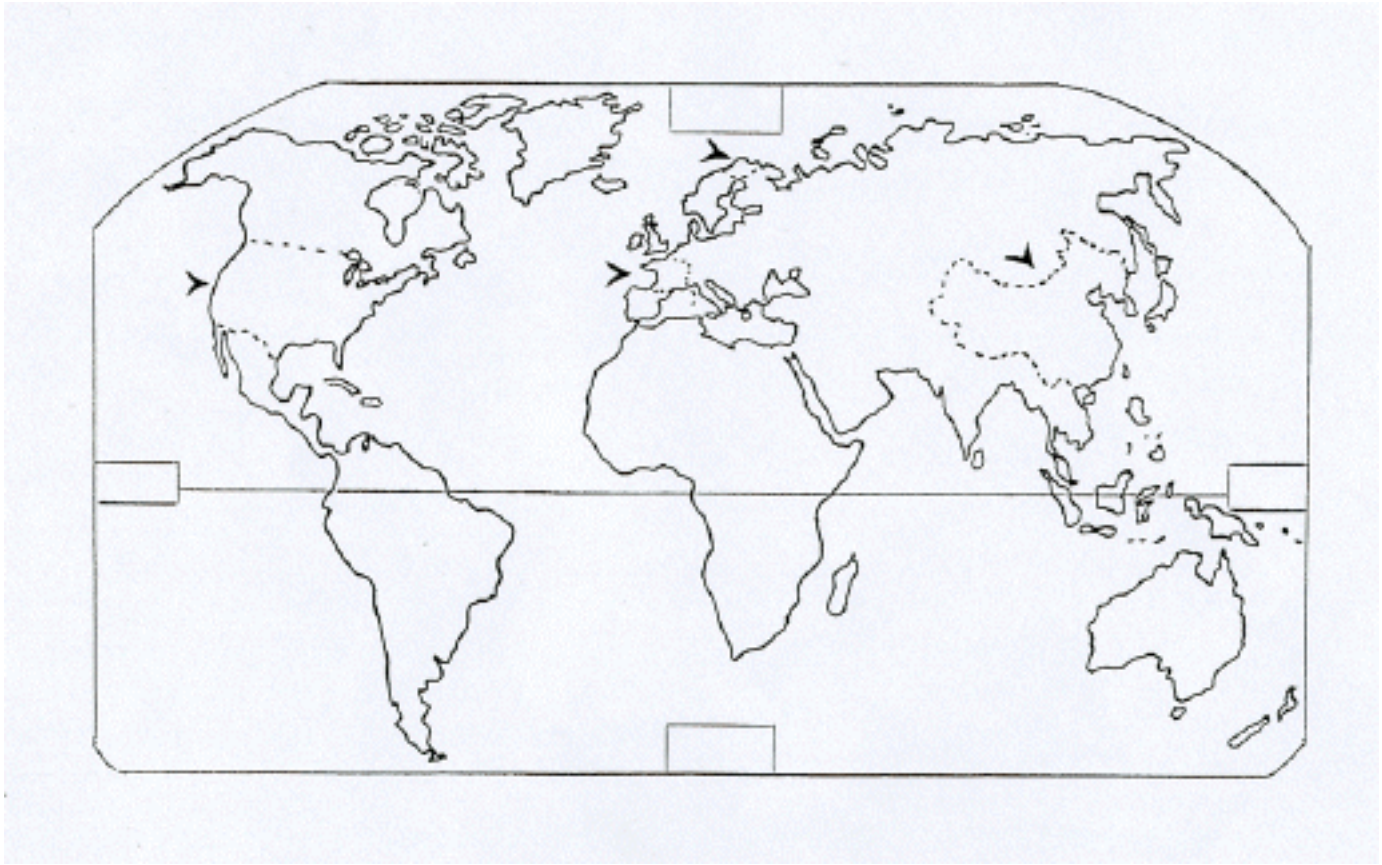

According to you, the United States are :

- West of France
- East of France

According to you, France is :

- West of China
- East of China

12– Look, the Sun is rising!

Do you know in which direction we see the Sun rise?

North South East West

Do you know in which direction we see the Sun set?

North South East West

13– The Sun is shining in my eyes !

Picture yourself standing, facing the sea or a vast plain, with the Sun in front of you, high in the sky. At what moment of the day can you see it like that? _____

In which direction can it be at that moment? _____

Draw a line representing the horizon, and then in the middle and high up, the Sun in the sky.

Draw the course of the Sun From dawn, when it rises, to dusk, when it sets.

On account of your answers at questions 12 and 13, try to locate the cardinal points.

Last, draw arrows on the course of the sun.

14– As the days, the nights and the seasons go by...

Do you know why, in France, the nights are longer in the winter than in the summer? _____

Do you know why it is cold in the winter and hot in the summer? _____

COMMENTARIES FOR THE TEACHER

Concerning the answer to question n°1, it is possible to meet different types of mistakes :

- No Sun

- Bad positions of the Sun, the stick and the shadow.

- A shadow that is not linked to the bottom of the stick

- Details in the shadow.

- A shadow that is as big as the stick. It is not a mistake because this situation can take place but it shows a tendency to consider that the shadow is like an image, a reflection.

Concerning the answer to question n°9, we can consider that, according to theoretic physics, that the choice of sentence 2 is also correct since the Earth and the Sun have a movement that is relative to each other's. Therefore, it all depends on the reference you choose : if it is the Earth, then it is correct to say that the Sun revolves around it !

The pupils are often sure that the only correct hypothesis is the fourth sentence. It is very instructive, but very difficult to make them admit that several hypotheses explain the alternation of days and nights. To look at it in a different point of view, it is difficult to make them admit that there is no familiar phenomenon that would help them determine which hypothesis is right.

As well, about question n°13, if a student lead the course of his sun from right to left after having written that the East is on the right for the sunrise and the West on the left for sunset, and that therefor the North is where the Sun is the highest in the sky, we should keep in mind that the drawing is not wrong out of context since that is the way it is in the southern hemisphere.

About the "mistakes" or "imprecisions" you will heighten in several answer drawings, you might prefer to be rather circumspect : the pupil may have a rather correct conception but may not know how to put it correctly on paper, for numerous reasons : foolish mistake, clumsiness, inability to draw in three dimensions on a piece of paper... Therefore, don't hesitate to ask the pupil to check.

It would be better, on our account, to make a rather "transversal" evaluation, counting the number of students that answered right at a question, and then making out the nature and the frequency of the mistakes found in the answers to that same question. That work seems much more interesting to us for the following sessions.

Nevertheless, for each pupil, why not establish some sort of qualitative "profile" finding his strong and weak points in each of the fields involved? The profile will of course be confronted to the one of the post-test at the end of the project, which could well be... the same questionnaire!

Sequence 1

Discovering the experiment made by Eratosthenes and trying to reproduce it

Introduction

This sequence is crucial since it corresponds to the beginning of the project which will last all over the year until June the 21st. It is preferable to follow the steps as suggested hereafter, starting with an experiment at Sun. However, last year the experiment showed that the Sun can disappear from our sky for several months without ever showing even its weakest ray. If after several weeks you have not yet started because of a poor weather, you can reverse the sessions 1 and 3 (experiment in the classroom with electric torches) and come back to the works outside later.

We wish to draw your attention on the importance of the written traces, which constitute one of the great principles of *La main à la pâte*. We suggest you, for example, to ask every student to keep a science notebook like you would keep a diary. They will all write down what they understood, discovered, what they wonder, the hypotheses they venture to answer the numerous questions they ask themselves as the activities go by. That notebook will also gather the drawings and diagrams related to the experiments they carried out. You will therefore be able to check that the child has understood and to follow his evolution during the year.

Preparatory session (optional) : It consists of activities related to the relations between a light source, objects and their shadow cast on a screen. If you think your students, after reading these experiments, need a preparatory session on these notions, we recommend you to refer to [the optional sequence](#) about the throwing of shadows and their relation to the light source.

Preliminary : The observations made by Eratosthenes (fictionalized historical text)

Duration : between 15 and 40 minutes of presentation (work on the text)

Once the pupils are divided in groups of four or five, give and make them read the following text at school, accompanied by photocopies of the map of Egypt :

"In Egypt, about 2200 years ago, a papyrus drew attention of a certain Eratosthenes, then Director of the Great Library of Alexandria (a town located on the side of the Mediterranean Sea): it was about a vertical stick which, on the first day of summer (that is to say on June the 21st) and at noon local solar time, did not cast any shadow on the ground (the Sun's rays reach the bottom of a well!). This happened very far from Alexandria, straight to the South, in a town called Syene (now Aswan). However, Eratosthenes noticed from his side that in Alexandria, on June the 21st also and at the same time, a stick vertically driven in the ground did cast a shadow, even if such a shadow was relatively short.

What the hell was this mystery?

We invite you to discover it by yourselves. This will lead you pretty far since, as Eratosthenes showed, the key of this mystery will allow you to measure the circumference of the Earth, nothing less!"

At first, the children carefully mark the keywords of the text: character, places, date, the experiment and its protocol (objects, times, ...). After locating the country on a wall map, ask them to identify on the maps of Egypt the places mentioned in the text. Then explain them that you challenge them to reproduce Eratosthenes' observations inside the sunny schoolyard.





Summary of the sequence:

- 1) Reproducing the observations at Sun
- 2) Schematization
- 3) Modeling in the classroom with electric torches

1) Reproducing the observations at Sun

Duration : at least to 15 or 20 min for outside experimentation



Equipment :

For each group of 4/5 pupils :

- 1 map of Egypt photocopied on one A3 sheet
(or 2 pasted A4 sheets
 - 2 matches or needles or drawing pins
 - 1 pen cap
 - Adhesive gum, simple or double face adhesive
or paste
 - Half an hour of sunny weather!
-
-

At first they must reproduce the instruments mentioned in the text at a smaller scale. For this, they will represent the sticks by a choice of needles, drawing pins, or matches they will past on the map. Of course, one will have to make sure that these "faked sticks" are really vertically driven in the map. However, do not give them preliminary instructions and let them proceed by trial and error. You just need to mention them that their experiment will have to be absolutely identical to the one described in the text. In Aswan they can either represent a stick or a well using for instance the cap of a pen (perfectly cylindrical) fixed into the sheet.

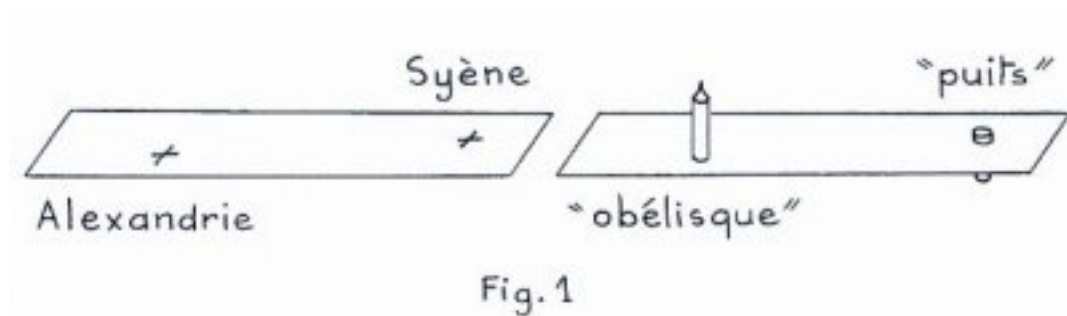

Ideally you could choose a reporter in each group. He would note the options adopted by the group and the strategy followed (the different trials, the reasons of their possible failures, and the hypotheses they have done). That sheet could be photocopied so as to be used as a first written trace in the science notebooks for the children of each group.

First challenge: Obtain a shadow in Alexandria and simultaneously cancel the shadow in Syene if they have used a stick or make the rays falling in to bottom of the cap-well if they have chosen the second option (if necessary, while the pupils experiment, make them notice that their sticks must not be tilted on the map ...).

The pupils will first see that they must orient the map towards the Sun for the shadow of Syene to disappear (or for the well to be fully enlightened). But then they discover that there isn't a shadow of Alexandria any longer ! Now there is a problem...

After a few minutes of trials and errors, the children will understand that they must curve the map to reproduce the observations made by Eratosthenes, what indicates that the Earth is not flat! Even if its rotundity seems obvious to them, they now have the feeling that they have found arguments in its favour.

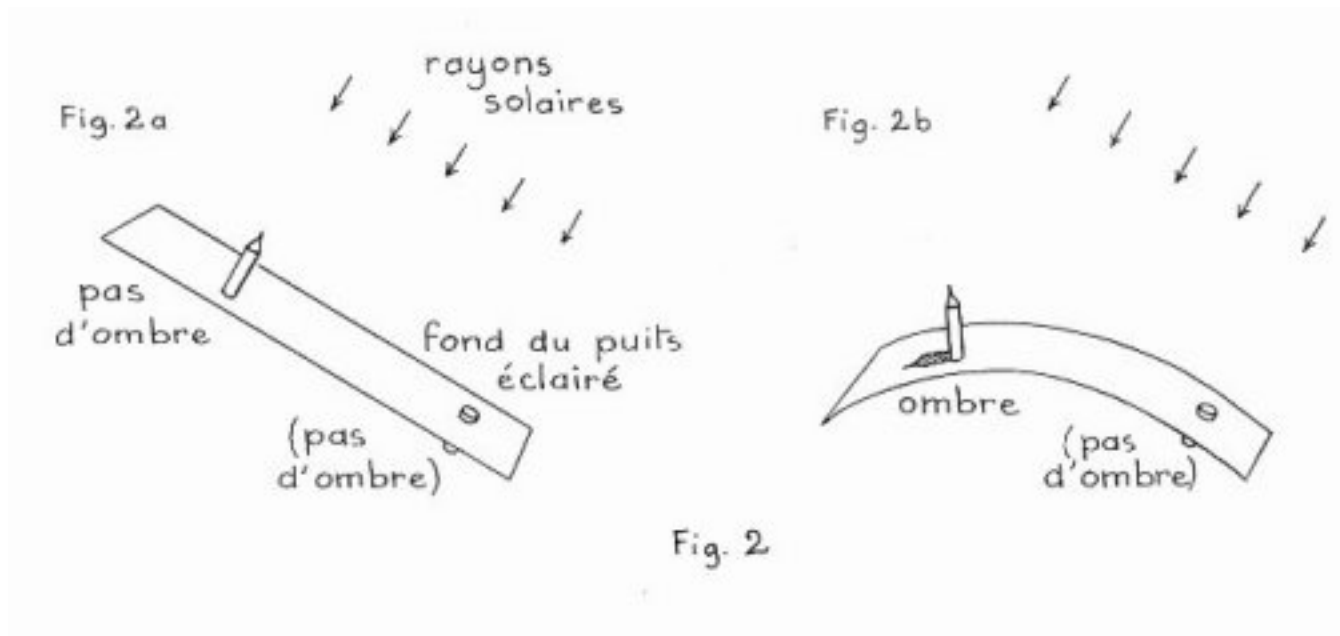

Second challenge: Vary the length of the shadow in Alexandria without a shadow becoming visible in Syene.

For that purpose, the pupils will have to curve the map more or less, and that way they will see that the length of the shadow of Alexandria depends on the curvature of the map and therefore on that of the Earth.

Third challenge: Vary again the length of the shadow in Alexandria keeping this time the same curvature. The pupils will then have to move away or closer the stick fixed in Alexandria and will understand that the length of the shadow is also linked to the distance between the towns.

During every challenge, each reporter should write down all the ideas and discoveries on their sheet.

2) Schematization

Note : immediately after so that they do not forget the results!

You can also place here the activities on the cast of shadows if the manipulations under the sun proved to be problematic for the children to understand. Don't hesitate to have them do again the first experiments before moving on so as to make sure they well memorized and assimilated them. Last, if this activity of schematization appears difficult to you, you may as well invert sessions 2 and 3, and that way you will insist on the manipulations with the lamps before moving on to the drawings.

Duration : Foresee 20 min in the classroom



Equipment :

For each group of 3/5 pupils :

the experiment book with the drawings, notes, and remarks that the reporter has written down during the experiment.

Back in classroom, each group tells the rest of the pupils its thought process, what allows to compare the different approaches followed by the teams.

This experiment has permitted them to show that the Earth is not flat and that the shadow of the sticks varies with the curvature of the terrestrial surface and the distance between the two cities.

Now ask everyone to carry out two drawings of the "experiment in the sunshine" with a representation of the two sticks (or the stick and the well) and the map in profile:

- the first one with a flat Earth: no shadow in Alexandria nor in Syene,
- the second one more conclusive with a curved terrestrial surface and a shadow in Alexandria

Tell them that the Sun's rays must clearly appear on their schemes and that they must be drawn with a rule. If this leads to questions or doubts in the class, you can refer to the optional activities on the propagation of light (see separated slip). Most of the pupils will draw the Sun on their sheet with divergent rays. Seize the opportunity to start the discussion with the pupils on the right way of drawing the Sun's rays. Indeed in this case the children will have to draw a shadow in both places, what does not correspond to what they have observed since there was no shadow in Alexandria when the map was flat (see figure).

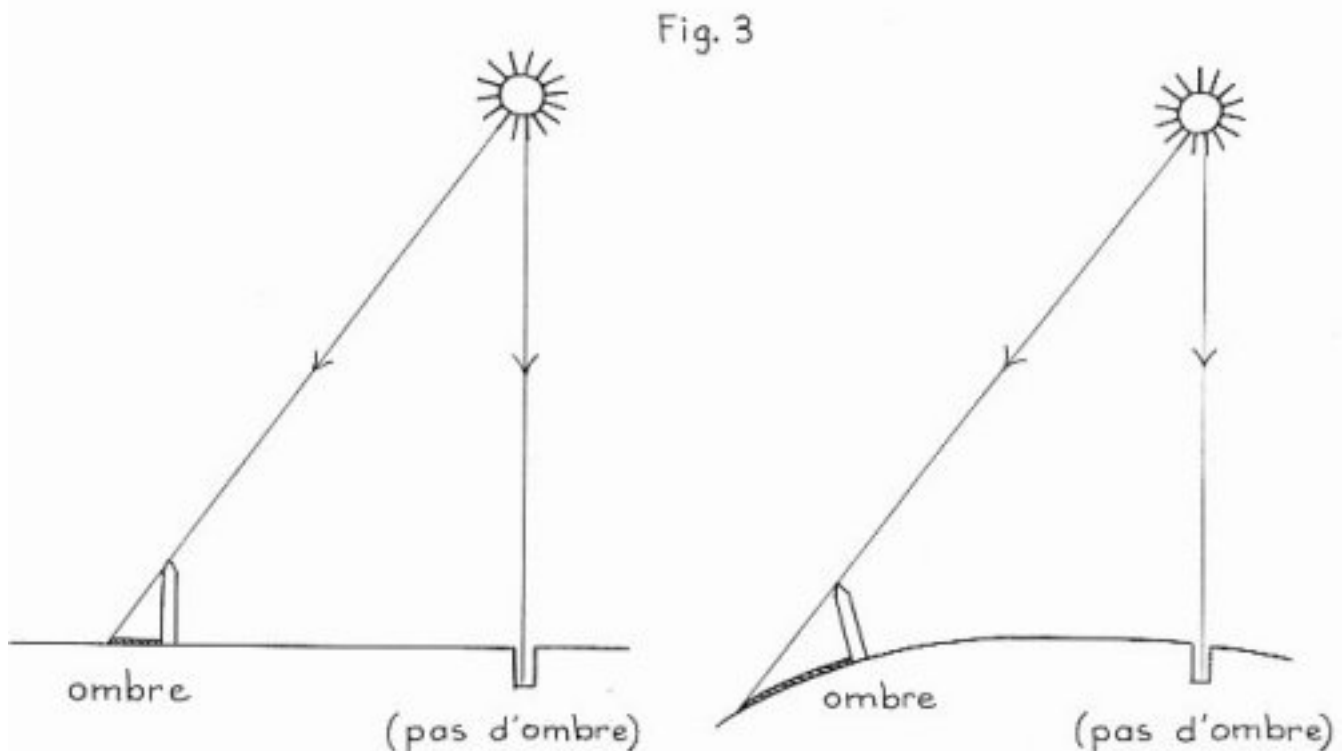

New challenge : "Look for how to draw the ray falling on the obelisk in Alexandria so that no shadow

appears any longer." One of the children will quickly answer that one has to right the ray until it is in the extension of the obelisk. Then what do they remark looking at the two rays of Sun? Both have the same direction and the gap between them remains constant. Here is what we call parallel rays. They have probably heard this word already.

Then, on the previous two figures, they draw in color the two parallel rays. They find again the observations performed at Sun with a shadow in Alexandria when the map is curved and no shadow in Aswan (the rays fall in the bottom of the well).

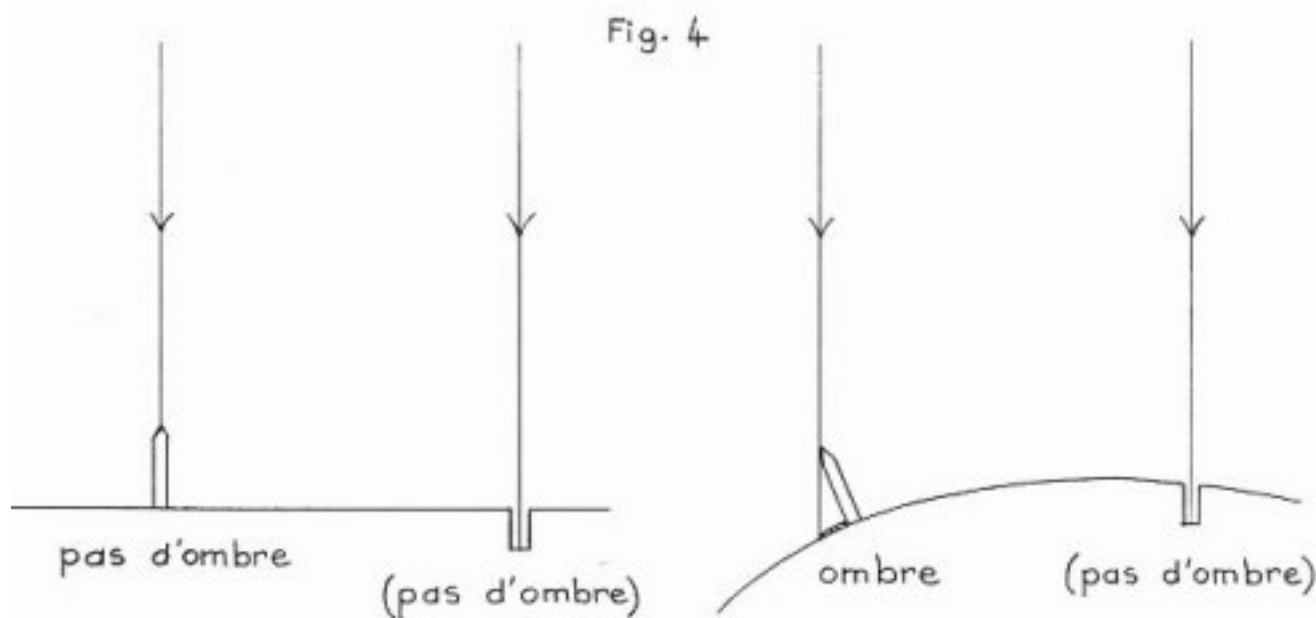

But are the rays of the Sun really parallel? How to be sure about this? One should go outside again to be convinced.

If you still have 15 minutes of sunny weather, you can end the session with the activity described further down under the caption "Verification in situ of the parallelism of the solar rays". You can also choose to use it as an introduction for the next session.

Finally, if you still have some time left, you can ask the children to draw the last experiments when they had to curve the map more or less, the sticks keeping the same separation and next conversely when at a given curvature they were varying the separation between the two sticks. You can for instance prepare figures on which the children will only have to trace the two solar rays (perfectly parallel now) and to draw the shadows. Hence you will be able to quickly check that each child has completely understood the experiments performed at Sun. Treasure the drawings and send us the best ones!

Fig. 5

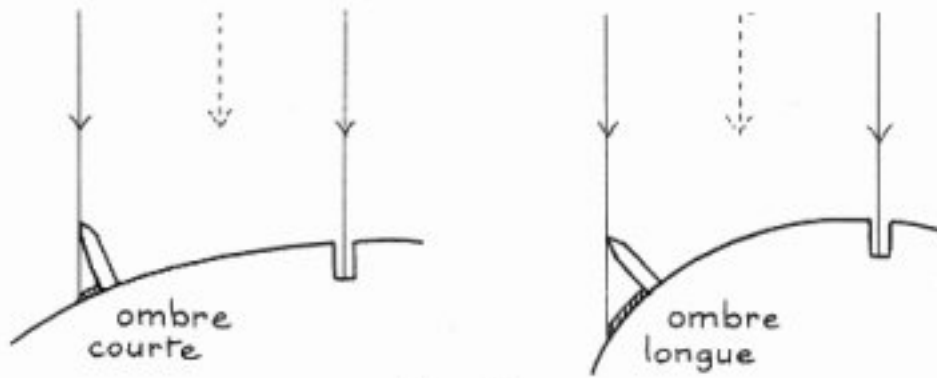

Fig. 5 a
courbure différente
même distance entre les lieux

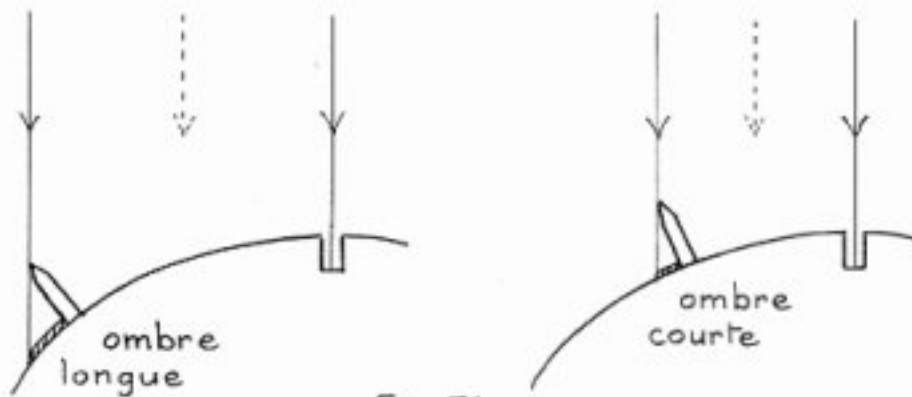

Fig. 5 b
même courbure
distance différente

3) Modeling in the classroom with electric torches

This simulation will allow the children to be confronted this time to the effects of divergent rays of lights. They will then discover how to have them evolve to a progressive "parallelism".

Duration : 30 to 45 min.

Location : Dark place, classroom and then outside



Equipment :

For each group of 3/5 pupils :

One torch, if possible putting away the reflector to improve the cleanness of the shadows

The map of Egypt and tyhe two sticks (or the pen cap)

Then for the following experiment:

3 drawing pins, not too small.

One sheet of squared paper.

This time the aim is to re-do the observations performed by Eratosthenes but with an electric torch instead of the Sun. You can also start the project with this session if the weather is really poor. Like during the first session, you will fix in a Bristol card or on a photocopy of the map of Egypt a stick or a pencil at the location of the two cities. You can also use the cap of a pen to represent the well in Aswan or any other object proposed by your pupils (see picture 1).

The challenge is the following: The challenge is the same: find again the observations lead by Eratosthenes. To do so, one will have to place the electric torch so that it enlights the bottom of the well (or that it does not cast any shadow in Aswan. By the way you can check that this is equivalent by putting the pen in its cap once the torch is correctly set). They will quickly curve the map as they have done outside, hence checking what our Greek scientist could see. But let us come back to the experiment with the flat map. What happens then?

When the map is flat the children observe that the pen in Alexandria does own a shadow. Exactly like in the first drawing they had done when the rays of the Sun were not parallel! This does not match at all what they have seen outside at Sun. But it then implies that the rays of the torch are not parallel...

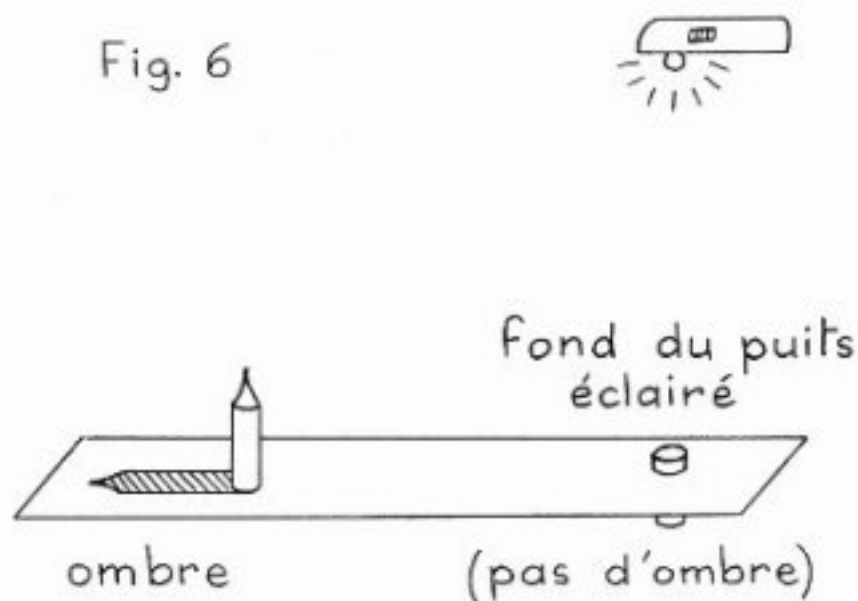

New challenge : how to place the lamp so that the shadow of the pen disappears? After several wrong trials one of the experimenters notes that by raising the lamp above the map, while keeping it completely above the cap in Aswan, the shadow of the pen decreases in Alexandria. If the lamp is brought closer, the shadow increases conversely. "What if one raises the torch until the ceiling, one could probably make the shadow completely disappearing?!". Then they try to move away the torch as far as possible from the map, then understanding that the origin of the light must stand very far away from the map so that its rays arrive totally parallel. What if it was the same for the Sun?

Schématisation de la simulation : From this experiment the students will prove with two sketches the link between the length of the shadow and the height of the light source: they may use a photocopy prepared by the teacher on which they will have to draw two lamps and two pairs of rays.

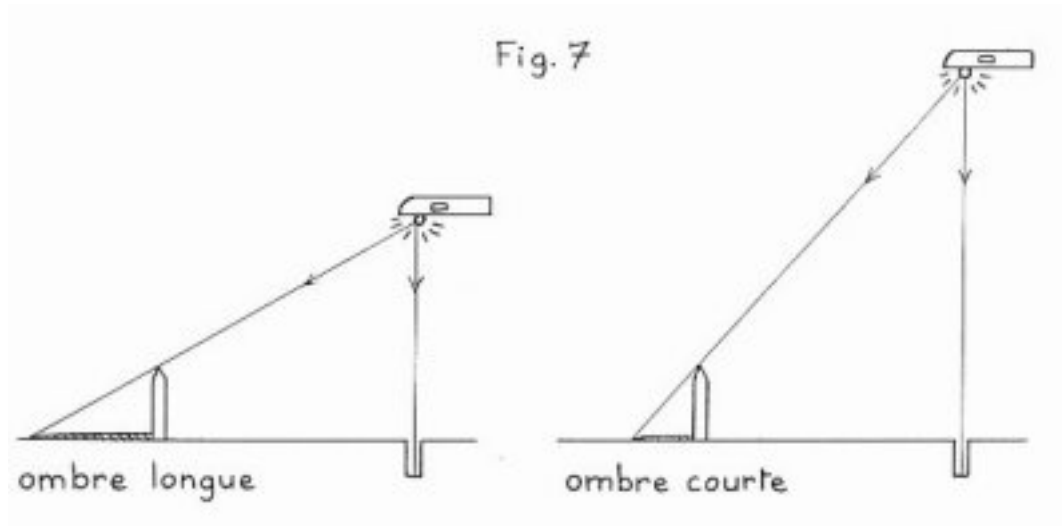

To be totally convinced of the parallelism of the rays of the Sun, you can end the session with the following activity or remind it to the pupils if they have done it already.

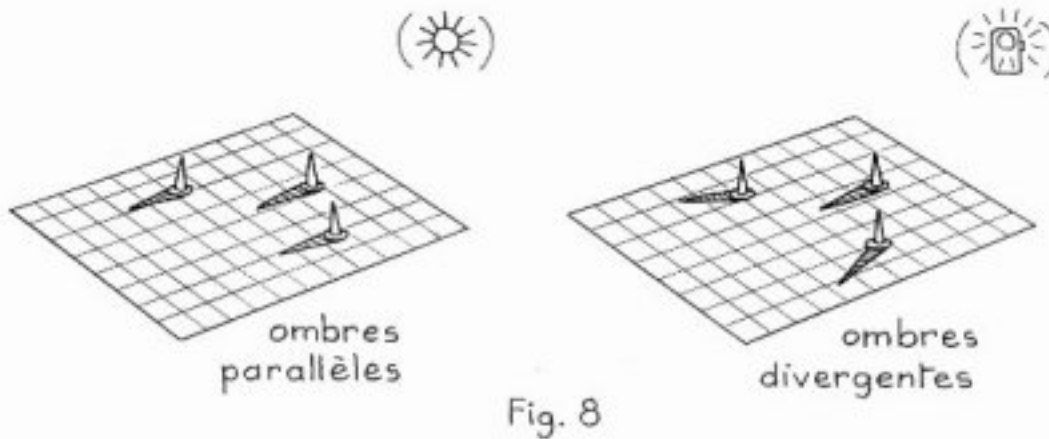

Photo : Huguette Farges, Compiègne

Verification in situ : Verification of the parallelism of the solar rays reaching the surface of our planet

The children observe that the lines of the square paper are really parallel. Then one has to check that the shadows of objects put all side by side on the sheet do follow the lines of the paper and hence are also parallel. This will prove that the rays which form these shadows are parallel themselves.

What happens if you use an electric torch instead of the Sun? The shadows diverge but they come closer to the lines of the grid if one moves the lamp away from the paper. Conclusion: the Sun is really far away from the Earth, so far that its rays reach us perfectly parallel! It is so far that one should better not to draw it on the sketches if one wants to represent its rays!



You can extend this session with the optional activities on the notion of parallelism.

Then don't hesitate to redo the experiment proposed at the beginning of this sequence leading to the rediscovery of the curvature of the Earth and allowing the children to find again the observations made by Eratosthenes. It will allow you to check that every one of them has understood the experiment under the Sun.

Then you will be able to recapitulate with the pupils on a large wall panel the schemes of the observations made by Eratosthenes with the two hypotheses on the Earth's shape, by drawing absolutely parallel Sun's rays this time so that you can conclude that the terrestrial surface is in fact curved.

NB : Maybe some will raise as an objection the fact that they already knew that the Earth was round! Thanks to this experiment, they have not proven that the Earth is round but rather that its surface is curved and not flat. Seize the opportunity to review the signs that allowed to assume that the Earth was round (at the time of Eratosthenes): navigators perched on the top of their main mast are the first to perceive the distant coastline; observers on top of a cliff have a longer view of ships moving towards the horizon than observers on the beach; the pole star is not at the same height above the horizon in Greece as in Egypt; finally during eclipses of the Moon, the shadow of the Earth projected onto the Moon shows a circular section. If some of the pupils have already observed the sky by night, you can evoke the sky mapping and the fact that some constellations (group of stars creating a figure, like the Great Bear) can only be observed in the Northern or Southern Hemisphere, the sky varies when one is moving on the surface of the Earth! The position of the polar star above the horizon varies also when one is moving on a North/South trajectory.

Complement : To extend this work, you can add a bibliographical research on Eratosthenes, the Great Library of Alexandria, Egypt and its fascinating history that the children will have to carry out for instance in groups, at home or in the classroom, with books or Internet. There is no lack of interesting topics ...



Optional sessions (Sequence 1)

Experimenting on the formation of shadows

Concepts tackled

The first concept to tackle in the Eratosthenes project is of course the rectilinear propagation of light as it directly concerns the formation of shadows. After that, the concept of cast shadows, and then diverge rays are dealt with. Then parallelism, connected with sunrays, as it is because of this characteristic that Eratosthenes was able to achieve his measurement of a meridian. Lastly, the correlation between the evolution of a shadow (length and direction) and the motion of the light source.

If you wish to know more about the concepts dealt with in this page, please read the "[technical assistance](#)" [page](#)

Sequence division

This sequence is divided into four parts. Each one of them fills several working sessions with very variable durations. Thus, one will be able to split them up or to gather them according to circumstances. Note that the time having to be devoted to the pupils' "hard copies" in their books of experiments will not be taken into account.

(Let us specify as well that the activities suggested in parts 2 and 4 take as a starting point the work [L'Astronomie est un jeu d'enfant, Le Pommier/Fayard](#)).

Sommaire de la séquence:

- [1\) Work on the rectilinear propagation of light](#)
 - [2\) Work on the shades and their relationships with the source of light](#)
 - [3\) The concept of divergent rays and parallel rays](#)
 - [4\) Observation of the shades evolution during the day](#)
-

1) Work on the rectilinear propagation of light

Duration : a one hour meeting, or two 40 minute meetings, according to the training of the pupils.

Place : on the one hand a partially shone upon room, on the other hand, a room that one is able to darken.



Matériel :

For each group of 3 to 5 pupils :

two small mirrors,

one torch ,

one black pencil,

one sheet of white paper.

A slide projector and a rag filled with chalk dust will be needed then.

Preliminary inquiry.

Generally, the children hardly wonder about the propagation of light, no matter what its origin is : that of the sun or that of an electric bulb (of a ceiling lamp for example): they have the intuition that the light is diffused around its source in all the directions since they are " bathed " in it, and that is enough for them. On the other hand, they intuitively understand that with a torch, things are different, because of the reflector " which sends its light only towards the object that one wants to lighten " : they specify then that its light "goes straight " to the meant object. In addition, if one questions them on the possibility of sending the sunlight " straight ahead" somewhere, some will surely think of the games that use a small mirror : " that one can send the sun to the eye of a classmate! "

Drawings before experiments.

Propose to the pupils to show by drawing what has just been said.

Some may have the idea of represent their luminous rays (rectilinear or not, arrow or not). Ask them whether they really can see that part of their drawings. Agree with the pupils that if that can be helpful to them, they can represent the rays. But as they are not seen, one decides to draw them in dotted lines...

Adopt the same representation then systematically.

If the pupils massively represent rectilinear rays, then it is necessary to ask them whether they are certain of that... If the opinions differ, it is in any case necessary to seek to find out who is right. That introduced the problems of the following paragraph.

Experiments

A first -rather short - time of experimentation can take place by a turnover of the groups : on the one hand, in a sunny place of the classroom, the children, using mirrors, " return the sun " to a darker part of the room, on a wall or to the ceiling, and observe the displacement of the luminous spot according to the orientation of their mirrors ; in addition, in an obscured room, the pupils observe the positions of the objects lit with their torches with regard to it, while evaluating the form and the extent of the enlightened zone. But they will also be able to try out the "returning " of the torch light with a mirror.

The rapporteurs of each group will probably confirm that the light is indeed related to rectilinear routes. But how to try to check that, for example with the torches?

Second time of experimentation: the pupils who have an idea undertake to carry it out after having gathered the necessary material. For the others, propose a white paper sheet, that they have to hold initially against a wall, in the part which is lit by a torch, so that the small very luminous central disc - that one will trace contour with a pencil on the sheet - is in the centre of this one (exhibit 1). It is then a question of slowly bringing back the sheet towards the torch (motionlessly!) by maintaining the small luminous round in the layout : the pupils notice that it is by a rectilinear motion towards the source of light that one can obtain that.

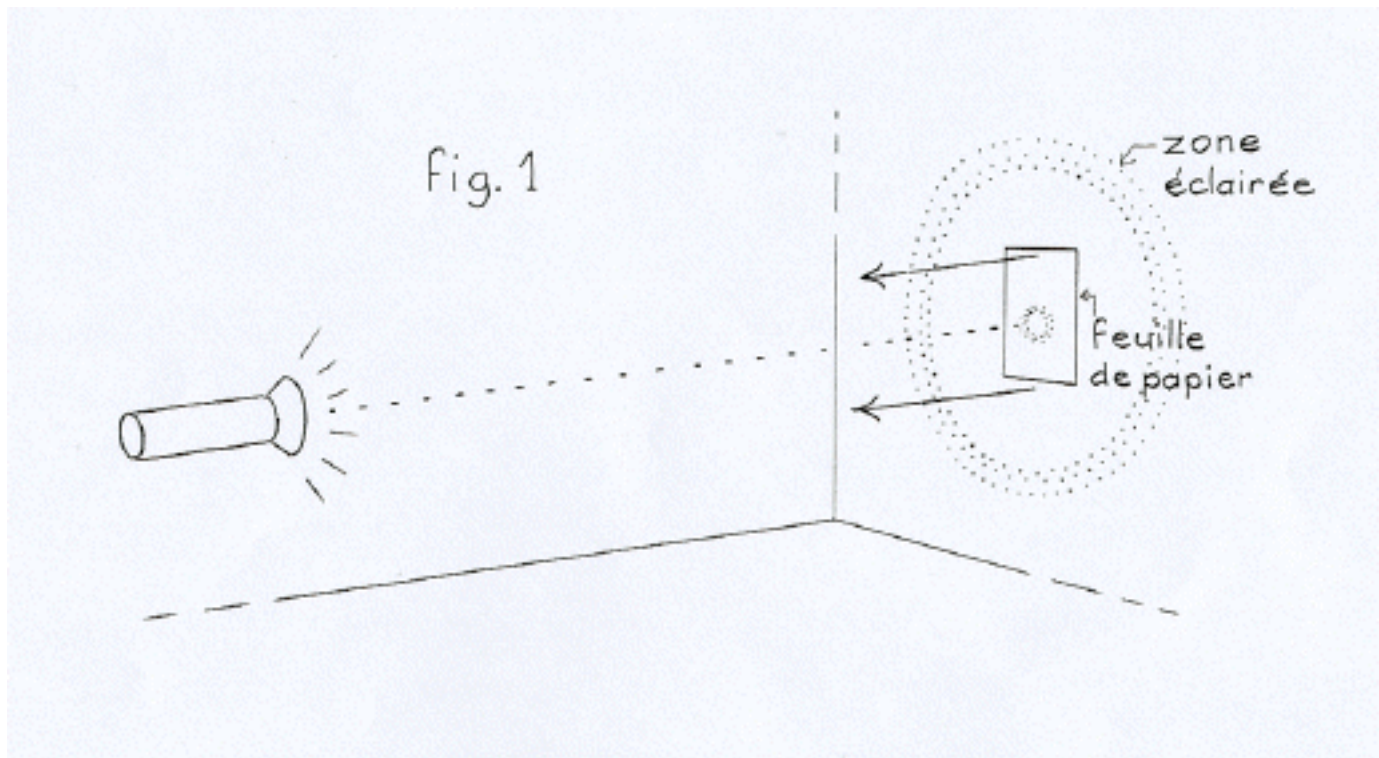

Photograph Huguette Farges (Compiègne)

Drawings after experiments.

Pupils make new drawings, they will probably be more complete and more precise than the former ones. They add a short caption to it.

To go further.

The children will have noticed that the luminous rays on the outlet side of the torches are not visible: it is necessary that an object intervenes in front of them, and thus "cuts" their way, so that the eye can see the lit object, which returns the light in one's eye (the best thing to do would be to do the experimentation again in a very vast and completely dark room). It will then be a question of calling upon the memory of the pupils so that they seek in which occasions they could perceive one or more rays of light : rays passing by a shutter hole in a room where fine dust is in suspension, sun rays through foliage by fog weather, headlights of a car by hazy weather, cigarette smoke in the beam of a projector...: one will point out to them that each time, there were fine particles. Indeed, those get the light of the source and give it out back to all sides (like the Moon does): it is said that those particles diffuse the light. One can highlight that in a very dark place, if one produces for example a small cloud of chalk dust by shaking a blackboard rag above the beam of slides projector.

2) Work on the shadows and their links with the light source

Duration : several moments of observation outside, depending on the weather ; a meeting of 20 min of laying out shades outside ; and another meeting for simulations inside.

Location : a sunny place where the ground is made of asphalt ; a place that can get dark.



Matériel :

For each group of 3 to 5 pupils :

a stick of chalk,
a dressmaker ribbon or a meter rule, a
calculator,
a torch,
a pencil or an elongated object,
some modelling clay,
a sheet of white paper,
a pencil,
graph paper.

Preliminary inquiry

After having expressed it by the drawing " of a stick to the sun " (in the quiz), the pupils say what they generally know about the shades and how they are formed. Then, one proposes to them to draw themselves " under the sun ", next to a tree and a house, according to their own opinion in relation with what was just said.

Confrontation of the drawings

The pupils, during the pre-test, have produced drawings with inevitable divergences. The teacher

reproduces those which show contradictory characteristics and first asks the pupils, in groups, to think of the mistakes which they comprise.

The observation of the following paragraph is more structured.

Observations

Those are done in sunny weather but also when the sun is slightly veiled, so that the pupils can note that the shades can be more or less clear, contrasted, and that they can of course disappear as soon as a cloud passes in front of the Sun. Their shape is related with the shape of the object itself according to the face presented to the sun (face, profile, three-quarter, above...).

Experiments

The children will find out that the shade, actually, is not limited to the two dimensions that one generally attributes to him: while passing their hands behind an object placed under the sun, or better, behind a classmate, they note that their hand darkens and that that happens whatever the distance between the child-object and the screen on which its shade projects (wall or ground): they find out that the shade has actually three dimensions but that it does not have a consistency by itself, it is an area in which the light coming from the Sun does not arrive. When an object interposes between a source of light and a screen, one can see on the screen a " shade " which one calls solid drop shadow. (As it will only be dealt with this one in all the following activities, it will not be necessary any more to give this precision).

Interpretation of layouts of shade

Pupils realize that their shade does not have the same " size " as themselves: how to check it? By carrying out comparisons using measurements of layouts. The children gather in binomials: while one faces the sun, the other traces the outline of his shade with chalk on bituminized ground, that, by including feet since we " walk " on our shade.

How to check now if the layouts are of identical size, larger or smaller than the stature of the pupils? Each binomial choose their process and carry it out (the easiest being to lengthen on one's own layout!).

Experimentations with a torch

Meanwhile, the pupils will have wondered about the cause of this difference between their stature and the length of their shade, and they will have understood that the height of the sun above the horizon is there for something. In order to be able to control the phenomenon, they will carry out simulations by small groups, with a flashlight and an unspecified object (a pencil planted on a ball of modelling clay being the ideal): they will soon have noticed the existing bond between the height of the lamp and the length of the shade of the object.

But it may be that a crafty one makes a lucky find coming to contradict this fact : he will put at the challenge his classmates to find the means of lowering or of raising their lamp without the shade obtained at the beginning varying in length (one will trace a reference mark on a paper sheet supporting the object). Exhibit 3 shows that the angle formed by the pencil of light and the sheet-support must remain constant: for

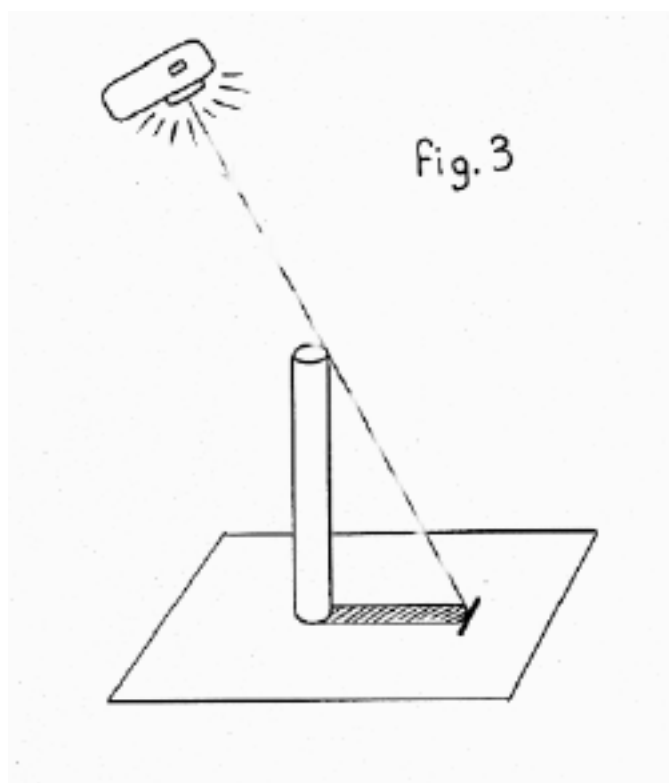

that, the lamp must be lowered, in a rectilinear motion, towards the top of the object (simplest being, of course, that this angle is equal to 90°): in this case, the lamp, during its descent, remains with the balance of the object from which the shade " disappears " then, as in the history of Eratosthenes!

And other pupils may also discover that, when the lamp is moved laterally, the shade makes in the same way " but with back! " They will find that back a little later...

Drawings with captions

The pupils consign their observations related to this part by sketches and captions. One can also ask them to reproduce on a 1/10 scale on graph paper, a character seen of profile having their stature, with his shade in front of him (thus seeming on the left or on the right on exhibit 3), and of which the length will correspond to their own statement ; they will seek how to place the sun in the most exact possible way : some will think of tracing the solar ray oblique passing by the top of the head and leading at the end of the shade, and they will prolong it upwards to place the sun there.

Note : If the pupils represent the rays, they should do that in dotted lines...

To go further.

It is possible that pupils wonder about the fact that contours of the shades appear more or less vague: they can, by very simple experiments, be brought to discover that this blur constitutes what is called the half-light, and that the formation of this one is related to dimension, specific or not, of the source of light. We will not detail these experiments here since the implied phenomenon does not intervene - or very little - in the Eratosthenes project. For the interested teachers nevertheless, let us announce that they will find all the details necessary in the Eclipses file of the site sequence [to initiate itself with the Moon eclipse](#) and sequence [to reveal the half-light](#).

Intermediate evaluation

One can envisage an intermediate evaluation, completely formative, to see whether, at this stage, the pupils acquired the concepts on which it will be necessary to be based later.

The teacher can propose a very simple drawing to them.

1. Out of cut, a roadway bordered of two pavements and an electric post on one of the pavements (THEY MUST NOT DRAW THE SUN!). Question : how to position the sun so that the shade of the post reaches the pavement of opposite?

3) Divergent rays and parallel rays concepts

Duration : a simulation of 15 min approximately ; experiments and measurements in outside of 20mn.

Location : a room which can darken ; a sunny place outside .



Matériel :

For each group of 3 to 5 pupils :

one torch,
three or four pencils,
some modelling clay,
one large sheet of paper , one
graduated rule ,
some thin string,
some tracing paper.

Simulation

The teacher makes a statement on the situation : several pencils will be raised on line on the table and a flashlight will light them from behind, then ask the pupils to anticipate : what will occur when you light the lamp? (the lamps have not been distributed yet).

Note : This moment of anticipation makes it possible to the teacher to evaluate what his pupils have understood about rectilinear propagation, and to the pupils to become aware the way they think. If, after checking, the experiment invalidates the forecast, the pupils will undoubtedly understand better the origin of their mistakes.

One distributes to each group of pupils the flashlights. This time, with their flashlight, the pupils light several pencils installed as on exhibit 4 but on a large paper sheet. They write down what they notice : the children who have aligned their pencils, by more or less parting them and lighting them from behind, immediately note that the shades " deviate towards the end ", more especially as the lamp approaches the pencils (exhibit 4a). They also see that while moving the lamp away, the shades " straighten out " but without being able " to get to do it, because the lamp is not enough strong and that one does not have enough place to move back again ". Ask them which source of light could be powerful and distant enough to check if the shades will be able " to straighten up completely " . At least one of them will end up thinking of the sun!

Note : *It is possible (but not sure) that the pupils notice that while moving away the lamp, shades straighten up . In the same way, one can ask the pupils if it is possible to obtain parallel shades. Once again, an anticipation sentence is interesting before experimenting (it would temporarily be necessary to take away the flashlights).*

If the idea of the sun appears, so much the better, but do not validate it. Keep it like an assumption. " Some think that with the sun, one will obtain parallel shades, what do the others think about it?... " If the idea does not appear, the teacher will ask the question : " how do you think that the shades will be with the sun?". That will make it possible to introduce the following experimentation.

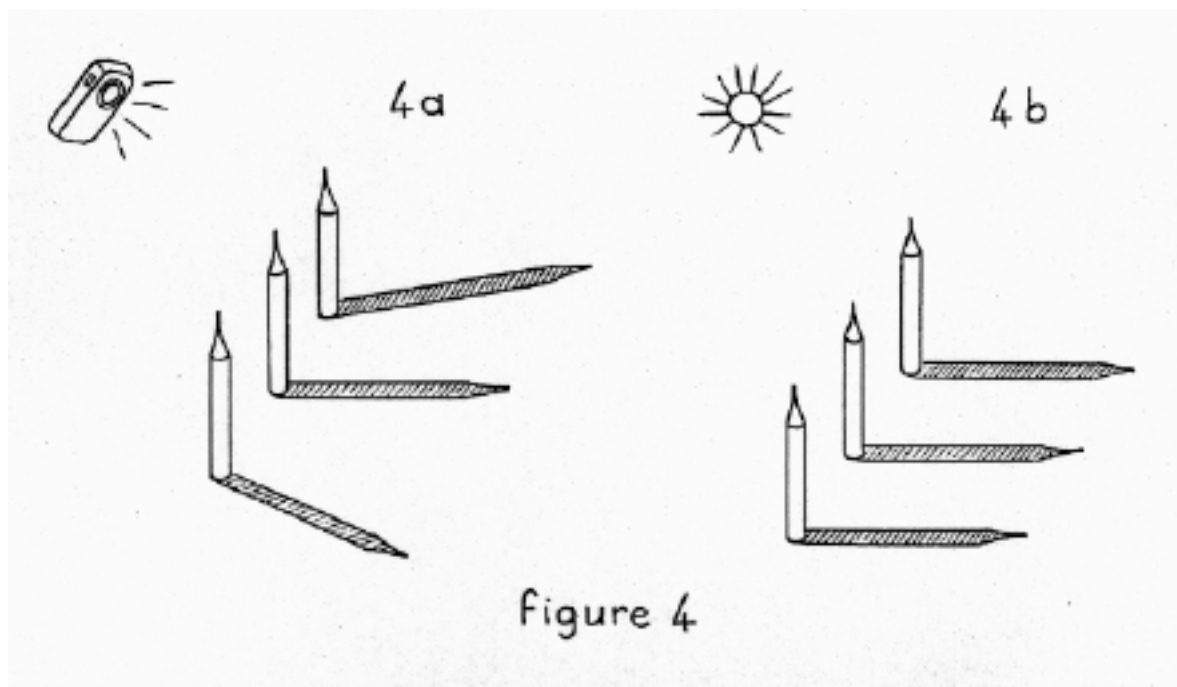

Figure 4

Outside experimentation

The pupils reinstall their pencils under the sun. Provided that objects are almost parallel (but not inevitably vertical), and that the ground is plane in that place (but not inevitably horizontal) they note that the shades seem " to have been completely straightened up " (exhibit 4b). The children having answered well the n°4 question of the quiz will perhaps remember the " parallel " word. How to check this parallelism? Some will propose to measure the spacing of the shades at their base and their end, " but only if the pencils have the same height", conditions which one will seek to obtain as well as possible, just as the parallelism of the pencils with one another. The installation will be done on a large paper sheet on which one will trace the shade of the pencils carefully, in order to carry out measurements once returned in class.

Measurements and interpretations

Measurements once carried out and compared, by admitting differences not exceeding the half centimetre per excess or defect, the pupils will show probable parallelism from the shades. Before they can deduce parallelism from the solar rays, they will have to make certain observations during two other simulations, initially with a flashlight, then with the sun.

New observations

First of all, how to see why the shades diverge with a flashlight? Remembering the sketch carried out on the graph paper, a few pupils will undoubtedly propose to materialize with string the way of the luminous rays on the basis of the lamp, passing on the point of each pencil, and leading at the end of their shade (practically, it will be necessary to seek the means of reducing the parasitic shades to the minimum generated by the strings on the level of the lamp glass and the end of the shades). The children will note that " it is because of the deviated strings that the shades also deviate " (exhibit 5a).

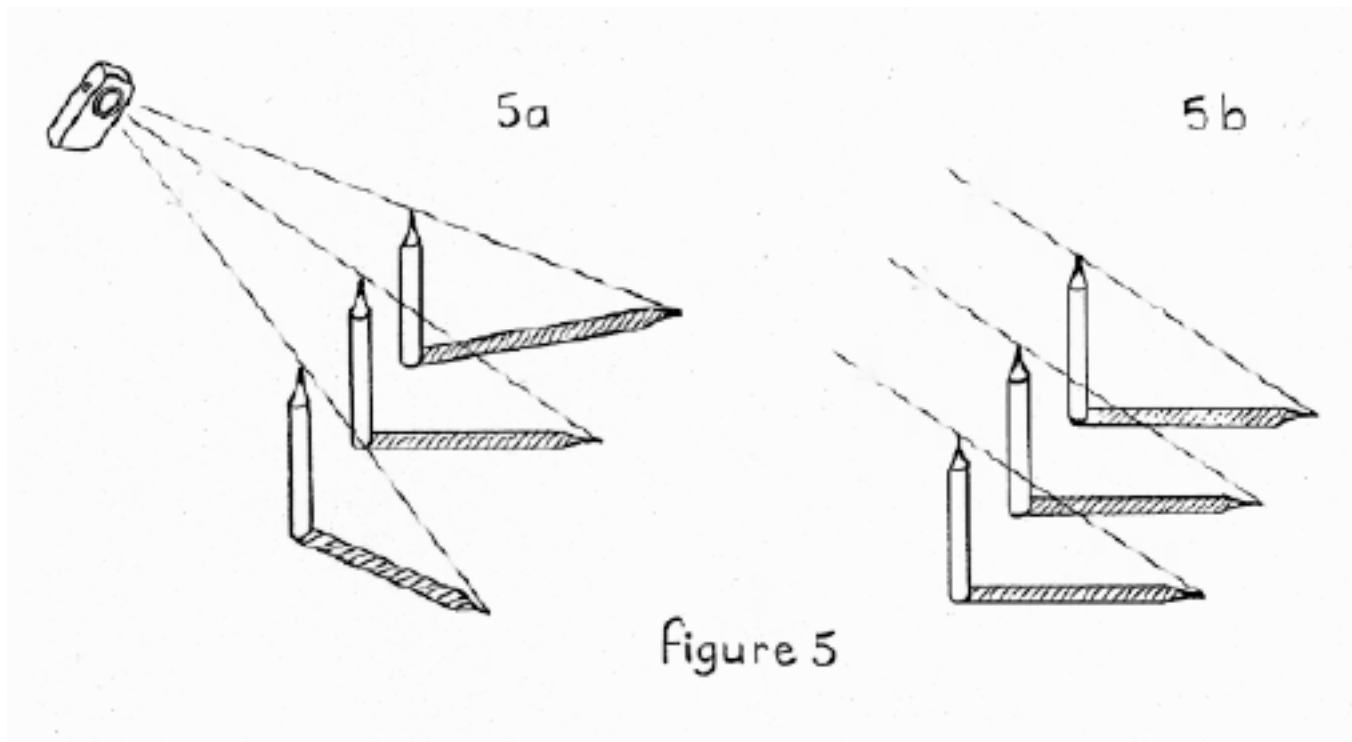

The crafty one will certainly add : " But then, with the Sun, the strings should be parallel! " (exhibit 5b). Of course, they will check that on the spot and will deduce from it that the solar rays must themselves be parallel.

Hard copies

The children will illustrate those discoveries by drawings and captions.

To go further

The teacher proposes to try to plot straight lines as parallel as possible, at a rough guess, then to check their parallelism in various ways, in which those:

The pupils reproduce on tracing paper a really parallel line network, thanks to the rulings of sheets of copies: this network, tightened enough, is posed then on the parallel alleged lines: while making one of those coincide with one of the network, that makes it possible to check the parallelism of all the others (exhibit 6a)

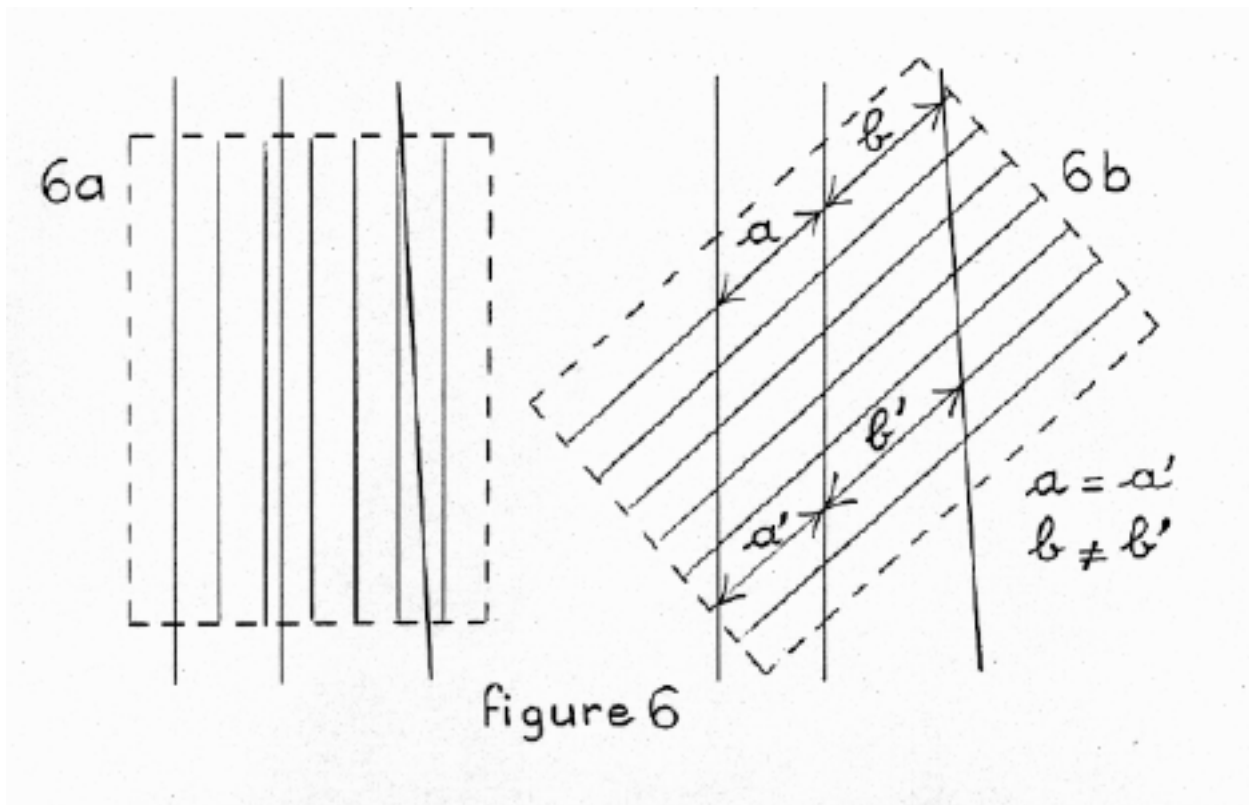

By putting this network, but this time in an unspecified way on the lines in question, then while carrying out for each one measurements of a couple of segments obtained, they compare the results (exhibit 6b). In addition, the pupils will see that it is easy to trace oblique parallels on graph paper.

4) Observation of the evolution of shades during the day

Duration : moments of observations and rather short layouts but renewed during one day ; meeting of simulation from 30 to 45 min.

Location : sunny place all the day, with bituminized ground ; place which can darken.



Matériel :

For each group of 3 to 5 pupils :

- a 10 to 15 cm length object which can stay upright or on a base of modelling clay,
- some stick of chalk,
- a large sheet of tracing paper,
- a marker,
- a torch ,
- a large sheet of white paper

Preliminary inquiry

Questioned on the variations of the shades during one day, the pupils are unanimous for saying that they will lengthen about the evening " since the Sun will lie down " They deduce from it that the morning, they must be very long also " since the Sun has just risen ". As for the rest of the day, they think that they are shortened initially until the moment " to go to eat at the canteen since the sun is all in top in the sky " to lengthen then. If one asks them to draw themselves at those various times, they generally only represent the variations of the length of their shade, with the Sun behind them at several heights, without representing an unspecified displacement of the star and thus of the shades.

Observations

To know some more, the pupils will observe the shade of elements located outside, under the sun, once in the morning, another time in the interval of midday and twice in the afternoon. If the variations of the length envisaged prove to be exact overall, the fact that the shades change direction at the same time, surprises them initially. But they quickly understood the cause of it: " It is because the Sun changes place in the sky! ".

Layouts of shades

How then, to locate precisely the evolution of the shades during one day, and to keep its trail? By drawing the shade of the same object at various times! The pupils, gathered in small groups, choose an unspecified object (but not exceeding a score of 20cm height) and put it on the ground in a place shone upon throughout the day : if the object cannot remain in place, they draw with chalk the contour of its base in order to be able to replace it exactly at the same place later on and with the same orientation.

Approximately every hour, and in turn, a member of each group comes to carry out the new layout of shade. At the end of the day, all the pupils go back to the site to note that the shades " turned " around the base of the objects, while changing length. Then, some must transfer, on large tracing paper sheets, their series of layouts of shade for a forthcoming use.

Caution : After the departure of the pupils, the teacher, using a compass, will discreetly locate the NORTH-SOUTH direction on one of the series traced on the ground, then he will do the same on the corresponding calk, we will see why in the following sequences.

Drawings with legend

The children try as well as possible to translate the observed phenomenon. Some have the idea of drawing as many small suns as there are layouts of shade, while trying to place each one of them in opposition, thanks to ray tracings passing by the top of the object and leading to the end of the shade, proving thus that they understood the implied mechanism well.

Simulation

It is now a question of reproducing the phenomenon observed in its double dimension: variation of the length of the shades but also, and jointly, rotation of those shades. In an obscured place, the objects having been useful previously for the layouts shades are installed on a large white paper sheet. In each group, one tries to find back the movement of the lamp allowing to simulate, in accelerated, the apparent movement of the Sun! That is done in order to manage to reproduce at the same time the movement of the shade of the object and the evolution of its length. Certain pupils, remembering the effect produced by side displacement of their lamp behind an object, find the manner of curving this displacement to obtain the desired effects (exhibit 7).

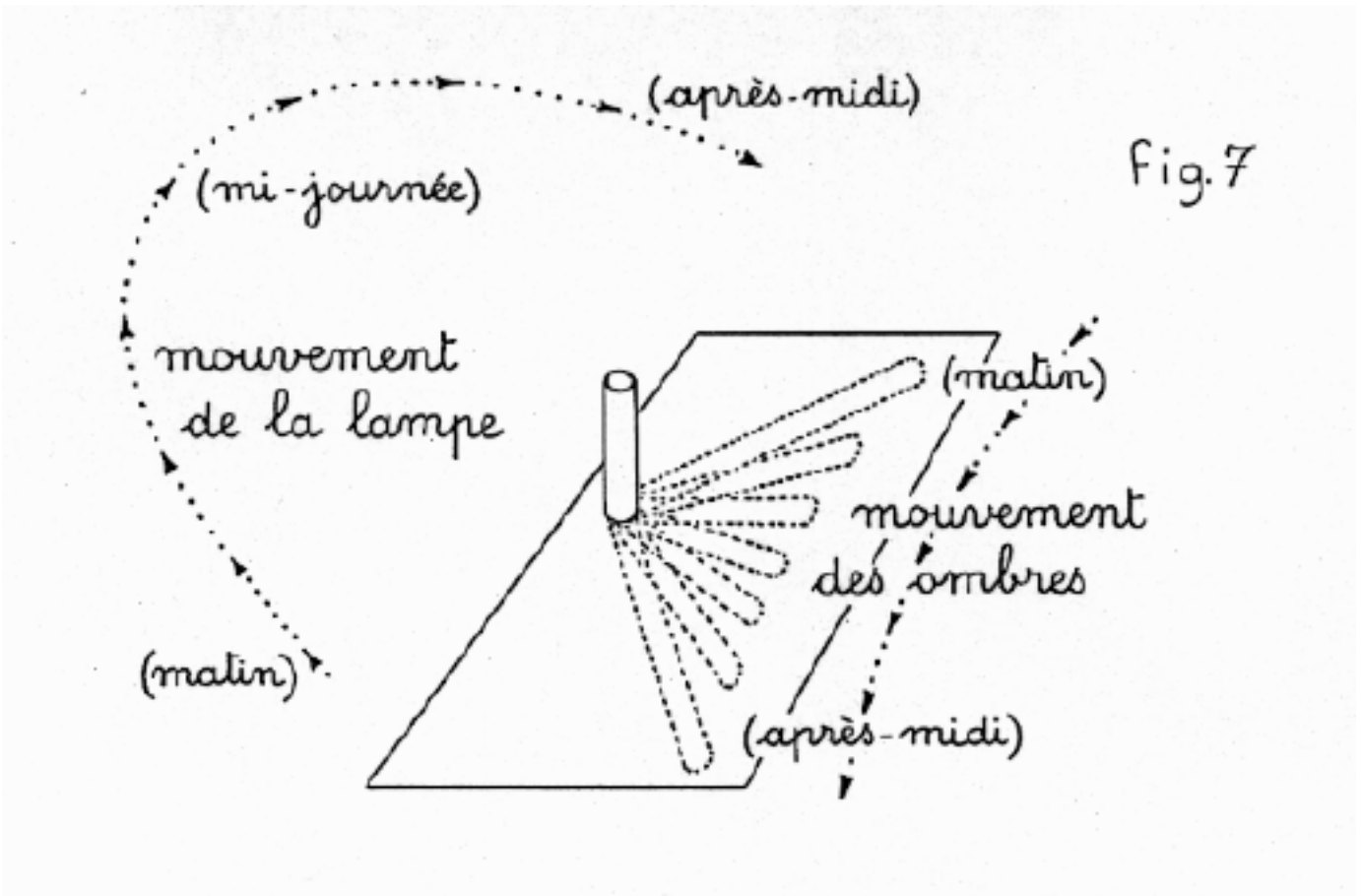

Then, while placing this time their object on the tracing paper sheet reproducing the layouts of its shade during one day, each pupil, in turn, tries successively to replace the shade of the object in each layout : in a discontinuous way initially, while groping more or less, then continuously, which requires a good coordination of the gesture and glance. Some reach that point rather well and are then praised to have succeeded in imitating " the true Sun! "

The following stage will thus consist in locating more precisely the apparent movement of the Sun.

Sequence 1

Technical assistance for sequence n° 1

Fiat lux !

These sequences, especially [the first one](#), involve a whole set of concepts linked to light phenomena (propagation of light, reflection, diffusion, shadows, and parallelism of light rays,...). We'll not tackle here with the very nature of light, but we advise you to carefully read the following points in order to spare you many predictable problems...

How do we see light?

Unlike what many children think, we can see an object because light rays left its surface and got into our eyes, not the contrary! It is difficult for them to realize that an object that is not a lamp or the Sun can "send" light by itself.

To understand that concept, we have to establish a clear difference between two types of sources : those that produce light (candles, filament of a light bulb, Sun) and those that reflect a light that hits them (any object and living being around us that we can see). So, a usual object that do not produce light can only be seen if it is lit and if the rays it sends back can get to our eye. If you are interested in the principles of sight, you can read the file about [the eye](#).

Propagation of light

In order to understand how light is propagated, you have to know the milieu it gets through (vacuum, air, liquid or glass cube,...). The most simple is in a homogeneous milieu, which properties (temperature, pressure, composition) are the same at every point. In such a milieu, light is propagated in a straight line provided it does not encounter any obstacle, and consequently follows the path adapted to the shortest time course.

If the milieu is not homogenous (for example when there is a great difference of temperature within the milieu), the shortest path (in time) is not the straight line any more, but a kind of curb. That explains, for example, the existence of mirages. And when a light ray gets into a different milieu (from air to water, for example), its course changes. You can easily see it by putting a staff into a pool of water : the stick seems "broken" because the rays that get to us from its immersed part are all suddenly deflected when they get into the air and then our eyes. This very simple fact inspired the physicist Descartes [his famous laws](#) about reflection and refraction (passing from a milieu to another).

You should now make the difference between transparent milieus (air, glass) that let at least some part of light pass through them and opaque ones (wood or metal) that stop them.

Encounter with an obstacle and shadows

Diffusion of light

When a ray of light strikes an opaque object, it is partly reflected by its surface. Take a mirror, in a huge room in total darkness and lit by a simple pocket lamp. The ray that strikes the mirror seems to be reflected towards only one direction, which depends on the angle made by the mirror and the light ray

(turn the mirror and the reflection changes). This is a simple use of one of Descartes' laws, easy to see.

Let's get a closer look : the surface of the mirror is not perfectly plane : it is formed with a number of facets that reflect the light. On an average, if the mirror is well polished, nearly all the facets are directed in the same way, but some of them are inclined randomly and reflect the light in other directions. Anywhere you are in the room (if you are on the right side of the silver surface), the mirror can still be seen. This is the proof that the light rays coming from its surface have been reflected in every direction, even if they are not the most numerous.

This phenomenon is called **diffusion** : when a light ray strikes some point of an object (opaque or transparent), this point becomes a source of light, by sending light rays in every direction, which allows us to see it from the area on the source of light. Let's see now what happens on the other side of an opaque object.

Shadows

Let's try the following experiment : illuminate a tennis ball with a **point source**. A perfect point source does not exist in nature, so we can simply use a pocket lamp. The filament of the bulb being very thin and small, we can deem it as a point source.

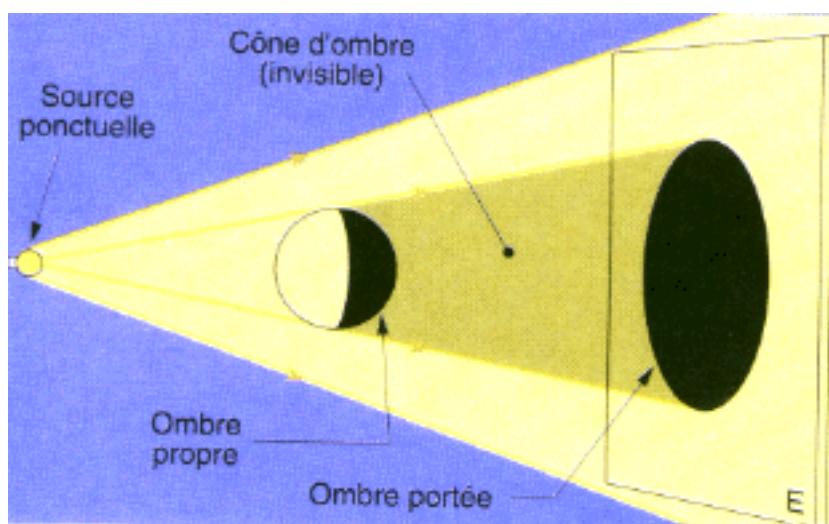

If we get behind the ball, in the area where the lamplight doesn't come, we cannot see the bulb. The whole area behind the ball is called **shadow zone**. The ball prevents the light from the bulb to get to it. On the screen, you can see a spot of shadow. Between the ball and the screen, there is an area the light rays from the bulb cannot reach. Actually, because of the spherical ball, it is called a **cone of shadows**.

When the light source is extended, which is nearly always the case (Sun, street lamps,...), on the screen appears a frontier between the illuminated area and the one in shadow : it is the penumbra. The eye cannot determine the exact line between the shadow and the penumbra. If you get into the penumbra area and look towards the source, you can see a part of the extended source (try it!).

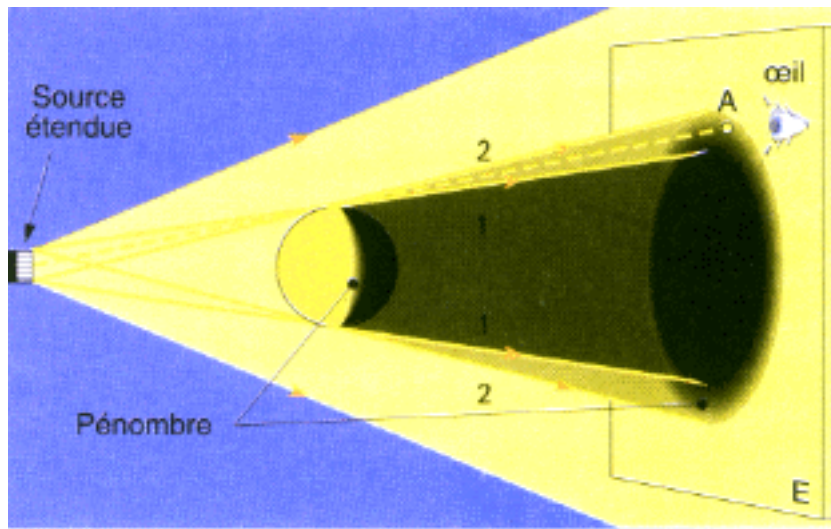

To get a graphic view of the shadow and penumbra areas, you only need to draw lines between the extreme points of the bulb and the one of the object (see drawing). No line leaving any point of the bulb can get to the shadow, since the object is here to stop them. Similarly, you will see an illuminated object only if there is a line going from the object to your eye, without any obstacle : get under a table and you won't see the objects upon it. But a few rays from the source get to the penumbra. If you put your eye (receiver) into the shadow cone, the eye will not see the source of light.

Let's replace the bulb of the first experiment by the Sun, the tennis ball by the Earth, and add a new factor : the Moon. If the Earth gets into the cone of shadow of the Moon and reciprocally, a well-known phenomenon appears : the eclipses.

The size and angle of a shadow can also tell us the place of the light source. And so, the shadow of a gnomon can precisely tell of the regular course of the Sun during the day. You can build a sundial thanks to this concept.

Traps to avoid !

Don't say "The shadow is the area that does not get light" : it is in general inaccurate, because of its imprecision : in most cases, there is always a surface (a wall, the floor, other objects,...) that reflect some part of the light towards the object observed. Then, our object gets multiple shadows even if they are not easy to see ! But, if you had an infinite black room without any wall (giving a real total darkness) and lit a staff with a lamp, the shadow of this staff would get absolutely no light.

In common life, the shadow created by the primary source is not necessarily without light, it is more accurate to say that it is the place from which one cannot see the light source because it is hidden by the object. The penumbra is the area from which you can see only part of the extended source masked by the object.

Parallelism and divergence

A major point in Eratosthenes' experiment : the parallelism of solar rays. How to understand this point easily?

The light rays emitted by a source are deemed parallel if the source is placed at an infinite distance from the observer. In practice, and without philosophical consideration about the concept of infinity, we'll consider that a distance exists (according to the dimensions of the source), beyond which we can tell approximately that the light rays coming to us are parallel between themselves.

The case of the Sun.

Let's take two rays emitted from the same point at the surface of the Sun, that strike the two ends of a two-meter high wall. It is easy to estimate the angle between these two rays, with the following ratio : height of the wall (2 meters) divided by the distance from the point on the surface of the sun (about 150 millions of km, so 150 billions of meters!). The angle found (expressed in a unit called "radian") is extremely small (you can imagine), and it cannot be seen by a human eye. As such, we can deem that these two rays are parallel.

Would it be the same for a department, a region, a country or the Earth itself? Change the height of the wall and use the distance you need (between two cities, or the North and the South poles) and see : in every case, you will find a very small angle. Consequently, we can deem that the rays that come to the Earth from the same point on the Sun are parallel.

But the Sun is not only a point : it is an extended source, widely extended, in fact. Its diameter is no less than 1.4 million kms! The light coming from the Sun is contained in a light beam, a cone which solar surface is the base and our eye the vertex (the point). All the rays contained in that cone are not strictly parallel between them, but make a small angle. The maximum angle is the one that divides the rays coming from the opposite rims of the Sun disc. You can estimate this angle the same way as before : the ratio being the diameter of the Sun divided by its distance from Earth $\sim 1/100$.

This angle (equal to 0.5 degrees) is almost negligible and it can be deemed at first that all the rays are parallel. But it is only a rough estimate : you only need to observe the shadow of a pen on a table to understand that the "blur" in the shadow is in fact the mark of the slightly diverging rays from the Sun. If the rays were absolutely parallel, the shadow would be perfectly clear, and the Sun would appear as a point in the sky. This is the case for the stars one can see at night : stars so far from us that their discs become a single point, and their rays all get parallel to us (or nearly!).

Beware!

Looking directly to the Sun is extremely dangerous, and you absolutely need to use special filters (goggles given for solar eclipses, for example). Painless but permanent injuries will be done to your eyes, but will be felt only a few hours or a few days after an unprotected observation. Tell the children about these risks : it is extremely inadvisable to look at the Sun without a protection. The special goggles will give you the opportunity to look at the sun disc and see its diameter safely.

A trap to avoid

Children draw sunrays as a crown around the disc, showing implicitly extremely diverging rays. Is it a mistake? Yes and no. The surface of the Sun sends rays in every direction (anyone can see it from anyplace in space), so the rays drawn really exist, but do not get to us! The majority of these light rays go through space towards distant stars, and only a very small part of them get to us (those contained into the cone above mentioned). To draw an accurate idea of the rays getting to the surface of the Earth, you should not draw the Sun disc, but the parallel rays that come to us. (to be absolutely accurate, we should draw around each parallel ray a small light cone to remind that Sun is not a point source!). Try to draw a scale map of the Sun and the Earth to understand the huge distance that separate them. Try it!

Sequence 2

Making and using the gnomons

Introduction

During this sequence, the children will discover that the shadow of a stick turns around and that its length changes during the day. They will then put under the sun their miniature self-made "obelisks", i.e. the gnomons, different at first, and similar afterwards. They will sketch and measure the shadows at five or six moments of the day. Comparing their results with those of their classmates, they will feel the necessity to stick their gnomon strictly vertical on a horizontal stand.

Notions

Global evolution of the shadows during a day. First line drawing and measures. First locatings of the direction of the shadows with regard to the North given by a compass. First comparisons. Notion of vertically and horizontality.

Preliminary : the obelisk of Alexandria

Show the following text to your pupils :

During the first sequece of this project, you partly solved the mystery of Eratosthenes. Here is the continuation of the story.

" Eratosthenes had learnt thanks to the papyrus that the stick stuck in Syene had no shadow and tryied to understnd this surprising phenomenon. He himself stuck a stick under the sun and observed it for long hours. As the stick wasn't straight up and the shadow was so tiny, he decided to observe th shadow of a big granit needle aised at the entrance of one of the temples in Alexandria. The needle was stuck very straight in the ground, it was nearly 20 meters high and cast a much bigger shadow than his stick, it was called the obelisk. Its summit was in the shape of a small pyramid covered with gold, so that it shone in the sun and you could see it from very far away! The obelisks often decorated the entrances of egyptian temples and pharaohs' tombs, Eratosthenes had no trouble finding one near his library. He observed it for long hours during the day and his observations allowed him to solve some of the mystery..."

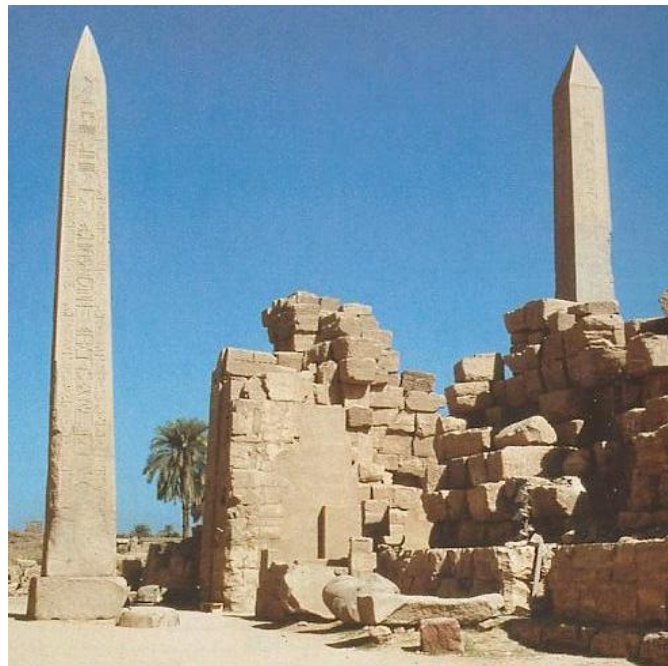

What did he notice observing the shadow of the obelisk during an entire day? It is your part to discover it doing the same experiment as Eratosthenes under the sun!

The children are brought to think about the instruments used by Eratosthenes to realize his experiment. Then they must ask themselves how to reproduce this experiment in their classroom and which instruments they have to build. But

before being able to build actual gnomons, they will have to put a stick under the sun, and observe in their turn the strange ballet of the shadows.

Since it had not been precised in the text the children read at the bigonning of the project, tell them that shade observed and carefully measured by Eratosthenes was that of an obelisk. Some documents will be welcomed to show what this "big granit needle" set up at the entry of the Egyptian temples looked like.

Then pupils will look for objects that can stand for a small-scale obelisk and bring them to school. But before then can create gnomons advisedly, they will have put a stick under the sun, no longer for a simple observation of its shade, but to answer the question raised by a strange precision given in the text: it was at a special moment, solar noon, that the measures had been made... Would this indicate that shadows change during the day ?

Duration : This sequence is made of four parts, each one of them can be done in one or two sessions, or in simple moments of activity during a sunny day.

Summary of the sequence:

- 1) Reading the variations of the shadow of a stick at different times of a class day.
 - 2) Making and using several gnomons.
 - 3) Making and using a few similar gnomons.
 - 4) Using the notion of verticality and horizontality to adjust the gnomons.
-

1) Reading the variations of the shadow of a stick at different times of a class day.

Duration : 5 to 6 moments of 5 to10 minutes during a sunny day to carry out the readings of the shadow outdoor

Location : endroit dégagé et bien exposé car devant rester ensoleillé toute la journée.



Matériel :

Pour la classe :

a stick (30cm minimum) stuck in a pot filled with earth or humid sand,
a chalk,
a tape measure,
two compasses,
a sheet of tracing paper,
a few straight objects including screw,
a piece of paper to take notes.

Débat.

The children first discuss this experiment and try to imagine what Eratosthenes could observe that was so remarkable. Every one elaborates their own hypotheses and will share his ideas with the classmates, and then writes it down in the science notebook. Some of them might remember the manipulations of the electric lamp over the map of Egypt and will assume that also shadows move when the sun moves in the sky. To verify the ideas that will have come up and part the candidates, only one solution, do yourself the experiment under the sun!

Installing a stick in the sun.

From the morning, you should place the stick in the pot in a place that remains in the sunduing school time. It will therefore all be about measuring the shadow at several moments of the day. But a question is set : if the shadow moves, how will we do to note the shift? "We will have to draw the shadow on the ground!" Therefore, you should put the pot on a hard floor (if it can't stay in place all day long, draw a line around the pot).

Discuss to agree on the moments of the observations of the shadow without disturbing the life of the class : for example, at the beginning of the morning break, then just before lunchtime, before class starts again, during the afternoon break and before the end of class. Moreover, if lunchtime is at 11h30, the pupils that have lunch at school will surely insist on staying for an extra observation of the shadow of the stick at "sharp noon".

Observing, drawing and measuring the shadow of the stick.

During the first observation on location, after writing down the precise date and time, a pupil is in charge of drawing the shadow with simple straight line running from the pot to the tip of the shadow.

Then, someone else will measure the drawing with a tape measure, and you will write down the figure found as some pupils note an important fact : the precision of the measure in relative because the shadow (pot included), very clear at the bottom, is blurrier as you reach the tip (even mre if the stick is long, due to the penumbra). And if the tip is very "sharp" (you can put a screw on top of it, pointing the sky), the pupils see - even better - that the imprecision is even more obvious! (As well, next time you go to the pot, they will bring straight objects of different length and shapes at the tip : holding them straight on the ground, they will see that the shorter the object is and the flatter the tip is, the better the precision of the shadow is, which they will remember when they make their gnomons).

During the second moment of observation (before which you will have stuck the two compasses in your pocket), they will notice: "the shadow has turned!", "And it is shorter!". The children then discuss to interpret the phenomenon : they quickly reach the agreement that the sun must have moved in the skyan that it is higher up than it was before.

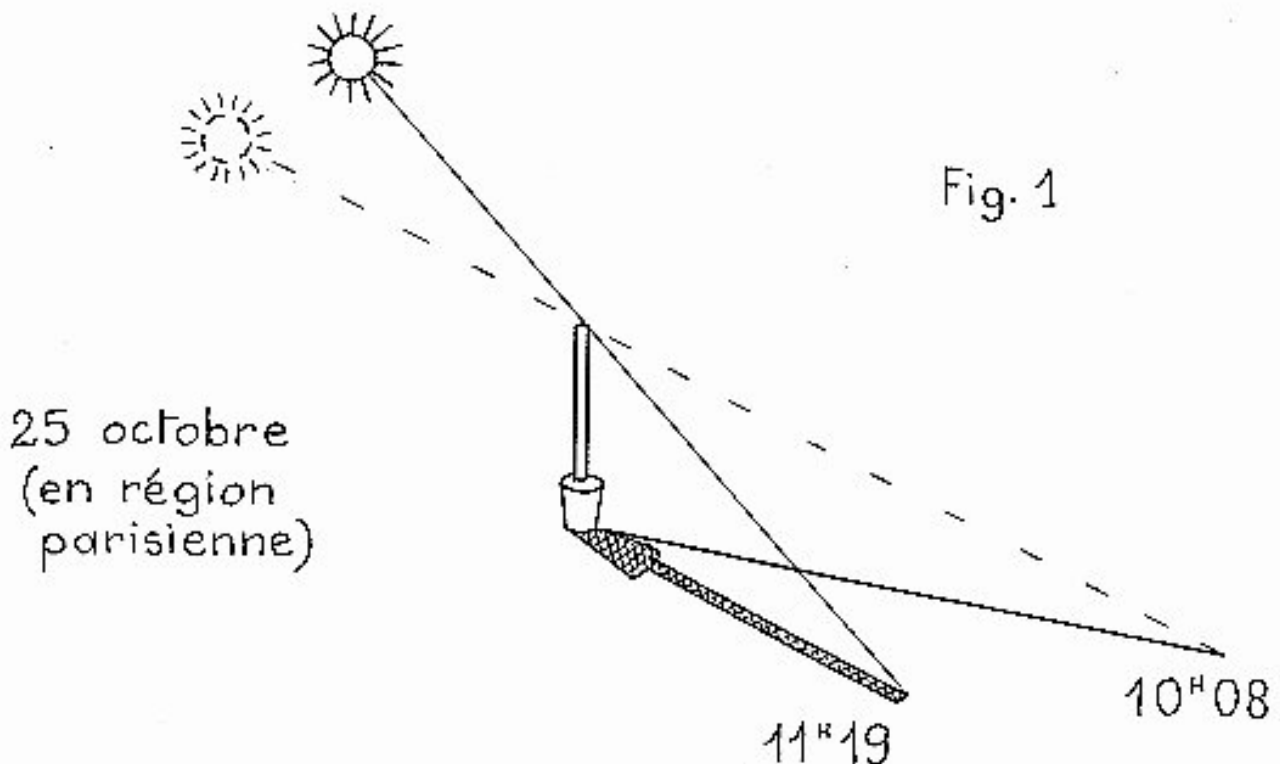

In the same run, they will try to foresee how the shadow will be at the moment of the next observation : if it is noon, they will think that the shadow will be shorter but that it will grow longer afterwards, until night time ; as for its moving, they will be sure it will go the same way "since the Sun isn't going to go backwards!"

Keep in mind the orientation of the two first shadow drawings, then the next ones. A question will doubtlessly emerge from the second time of observation or the following ones : if it is easy to read every time the length of the drawing, how will we do to store the "spread", i.e. the way the shadow turned around? the pupils first think of locating an object in line with each drawing (a tree, a door...), but it is unpredictable and not very accurate! Others will suggest to put a big piece of tracing paper under the pot in order to reproduce the start of the drawings. New problem : when the rain will have erased everything, how will we put the tracing paper back right if we want to carry on the manipulation again for later comparisons? Here comes the necessity to locate near the pot and then on the tracing paper a precise and everlasting direction, like the North, for example, that we find on the maps... "We would need a compass!"

Then make a quick investigation on the knowledge your pupils have of that instrument, and foresee a few activities to make them familiar with its use (see [activities with the compass](#))

While the pupils remark that the shadow already turned slightly while they were talking, take a compass out of your pocket. Ask a pupil to show the others how it works, when you put it on the ground : once the needle is stable, the pupil will make the blue arrow coincide with the letter N for each of the four letters of the cardinal points to be able to point at the four directions. The one from the North is materialized by an arrow (see image 2).

Remark : if you are in the South hemisphere outside of the intertropical zone, replace North with South in the continuation of the text because the sun will reach its height north in your case and the shadow of the stick will point south. If you are in the intertropical zone, it will be either of these cases depending on the moment of the year you do the experiment. As well, the indication of time in the continuation of the session correspond only to what we would observe in France in winter time. You have to adapt considering the moment the sun is the highest in your region.

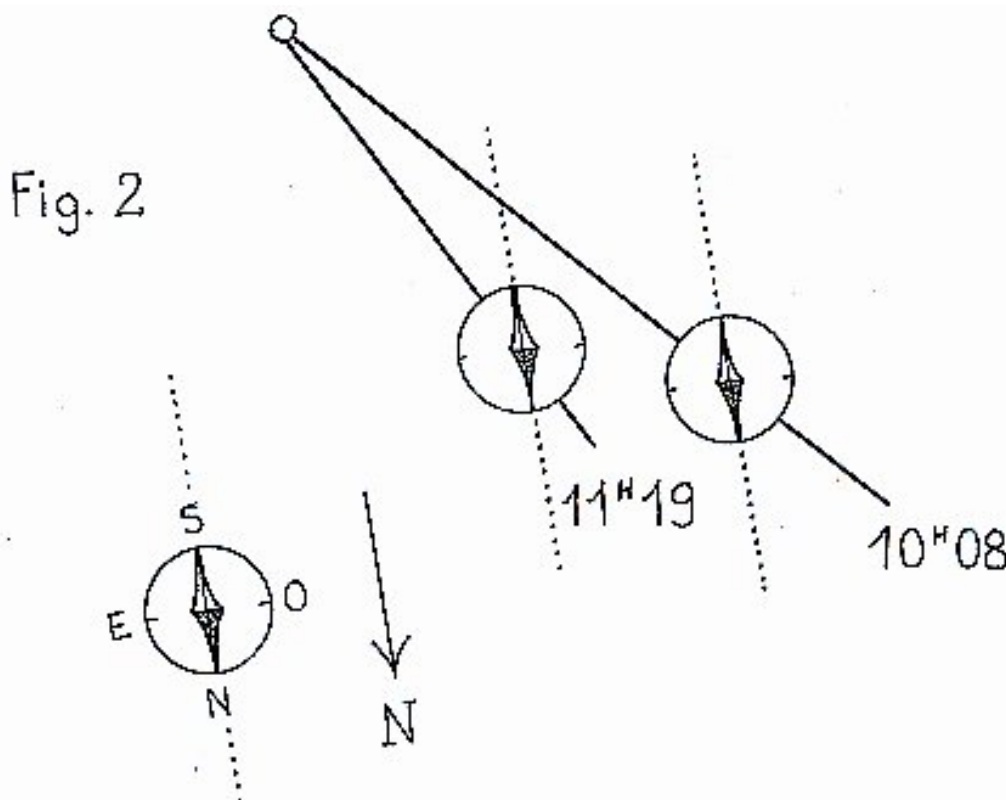

The children notice that both drawings don't follow the direction North : they suggest to place the compass (and the second one you will have taken out) on each of them to see how they "spread out". Some of them might add that the drawings are oriented North-East : it is not about making them determine precisely the orientation of the drawings - it is a very difficult thing for the children knowing nothing about angles - but locating how the shadow turns around in regard with the orientation North (which will remain in center of all further observations). Indeed, the children will foresee that the next drawing will approach that direction, which of course can be checked later.

The following readings. Let's remind that the third moment of observation takes place whether at lunchtime or when school starts again after lunch : therefore, we proceed to the drawing of the shadow on the ground and comment on its length and its orientation in regard with the first ones and the direction North. If the reading takes place at noon as some children might have wanted, the latter notice that the shadow is shorter and that it doesn't yet coincide with the direction North of the compass. They assume it will later. Until when will it shorten? Will it end up disappearing? At what time? What will happen later in the afternoon? Will the shadow grow again?

The pupils will then share their intuitions, they will write down in their notebook their observations and their answers to all these questions and will quickly make new readings to check the hypotheses.

If the next reading is carried out a little after 1pm, it will show very well that the shadow crossed the direction North but, however, will reveal that it is slightly shorter than it was at noon, but still there (except on the very particular case if you are in the intertropical zone and the sun has reached its zenith)! Then, the two last drawings will confirm the children's hypothesis, they will see the shadow lengthen again until gigantic proportions until sunset.

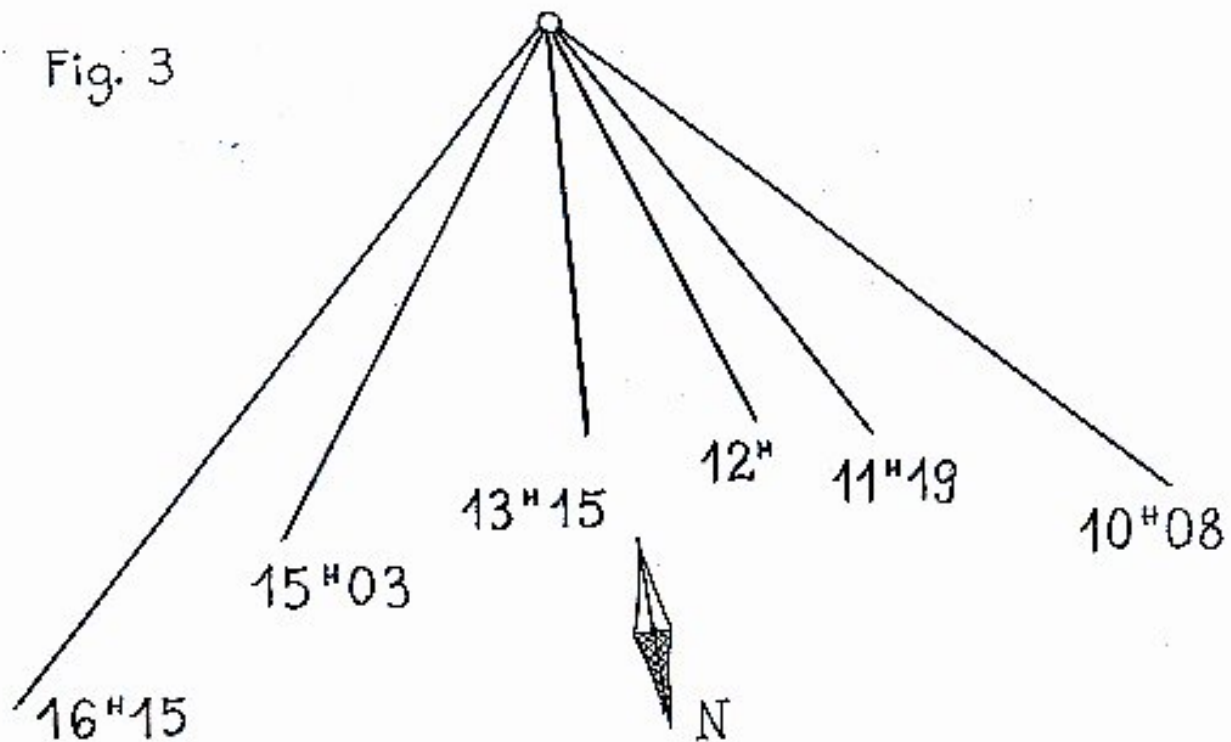

Before leaving the school, they will reproduce on tracing paper the "funny fan opening north", or at least the start of the drawings, including the arrow pointing North (or the needle of the compass) : the children will refer to it to sketch the readings on their notebook.

Keep in mind to save 10 minutes at the end of the day to take stock on the conclusions of the experiment. They have discovered what Eratosthenes had himself realized observing the obelisk > the shadows turn and change length depending on the time of the day. Some pupils may then refer to sundials used by the Egyptians. Then, they will carefully write down all the new questions that have come up with this experiment. After that, they might want to do the manipulation with miniature obelisks stuck on a large stand that can contain the wide morning and afternoon shadows. That's what the next sequence is about.

2) Making and using several gnomons

Duration : moment of concertation, short do-it-yourself time, and then, during a sunny day, 5 or 6 moments of shadow reporting, moment of exchange and discussion.

Location : classroom ; then, for the reports, sunny room all day long (oriented South) or a clear outdoor location.



Equipment :

For the class :

Objects brought in class to make the gnomons, i.e. the tiny "obelisks" (one for each group of 3 to 5 children), fixed on board-stands ;
appropriate tools ; a few gnomons previously made at home ;
a compass and a sheet of tracing paper for each group.

While the children will bring from home several objects to be used as sticks and plane surfaces, some of them will be proud to bring a manufactured gnomon with them! (You are advised to encourage your pupils to have a self-made gnomon at home in order to reproduce the manipulations carried out in class during weekends and holidays : the families will therefore be involved in the adventure!).

Concertation.

In groups, the pupils discuss to choose which of the objects they brought is most appropriate to make one or two gnomons. (It can also be decided that every child can make his own, but beware of the space required to expose around 30 not too small boards!) Making the gnomons : Some groups choose to stick their gnomon in a polystyrene board, or to stick a big rivet on a plywood board ; others simply stick with adhesive paste a pencil (whether they think of blunting it before) or a piece of a tube, on wrapping board, etc.

Remembering that the shadows are very long in the late fall and that the "blur" of their contour increases "at the tip", the children will be careful to choose a short gnomon, i.e. 10 cm to the most, to prevent the board from taking up too much space ; nevertheless, if the stand they foresee is not big enough or if they are not careful to stick the gnomon on a side of the stand, they risk to run over more or less... (indeed, in our latitudes, at the time of the solstice and of the local solar midday, the shadows, although as short as can be, reach two and a half times the size of the object!)

Written traces.

Each pupil will describe the instrument made by the group or by himself reporting the dimensions of the stick and the stand, but also what justifies his choices : why these materials? Why these dimensions? Did they voluntarily choose a round end instead of a sharp one?

Installation of the gnomons.

The ideal, of course, would be to have a room oriented South with enough space not too far from the windows to be able to set all the gnomons under the sun! (At this time of the year and during all the winter, the Sun, very low in the sky, penetrates widely in well oriented rooms). But, should it be indoor or outdoor, the first thing to do is to set the orientation of all the gnomons because, even those that can stand in place will risk to be bumped into. Each group will then test the way they oriented the gnomon by moving it and putting it back into the very same place. A sheet of tracing paper to keep precisely the drawing of the shadow will be temporarily stuck on the stands. The North will be materialized by an arrow.

Concertation and reading of the length of the shadow

Reach an agreement on the timetable for the reporting for the times to be similar to the ones with the stick under the sun. Nevertheless, to be able to compare the results of the line drawings, a child holding a watch will be in charge of giving the signal to start the reports. On the other hand, pupils may volunteer to check what happens between noon and

the time of the next report : they will delay the drawing carried out at "sharp noon" - judged as uninteresting - and starting the next one earlier in the afternoon to obtain perhaps that one of the drawings coincides with the North... During another sunny day, the pupils in each group will carry out the instructions switching the task between the members. Maybe they will encounter problems here and there : long shadows cut (the stick being too long for the stand, or placed wrong, direction North too far from the axis of the stand), difficulty to report accurately the axis of the shadow (stick being too thick or irregular), lack of precision in the reporting (stick still too sharp)...

Confrontation of the results.

Superimposing in two-two time the tracing papers of the complete reports, the pupils of course see that the shadows of the highest gnomons give longer lines. But, while noticing that the very wide ranges show that the shadows globally turned around the same way, they admit that important gaps question the precise orientation of several shadows : particularly the ones from mid-day, likely to approach most th direction North...

The children will argue and understand that the comparisons would be easier if the solar sticks were identical... To th question : "Do you think that if you start again the eperiment with the similar nomons and taking all th needed care, you will obtain similar results?" they will all answer positively! Defy them to check it out...

3) Making and using a few similar gnomons

Duration : short do-it-yourself session, then, during a sunny day, 5 to 6 moments of reporting the shadow ; moment of exchange and discussion.

Location : classroom ; then, for the reports, a room which is sunny all day long (oriented South) or a clear outdoor location.



Equipment :

For each group of 3 to 5 pupils :

a toothpick,
a 18 x 25cm cardboard sheet (or a " carton-plume ") ,
a measuring ruler(10cm long)made out of
graph paper pasted on a Bristol board rectangle,
a sheet of tracing paper,
a compass.

Making this half a dozen instruments more or less will be very simple and fast: the rod will consist into a simple toothpick for instance, but unpointed at one end (which will be used for the reference marks) to obtain for example a length of 5.5 cm. The pointed end will be completely drkiven into a plate of 5mm wide corrugated board: in our example, this will give a 5 cm height to all the solar sticks. Hence the support could have reduced dimensions, that is to say 18 x 25 cm. Before sticking the toothpick, one will fix, temporarily though, a tracing paper sheet: the pupils will remember that tracing paper allows immediate and straightforward comparisons, by simple superposition. Before and after the readings, one will take all the precautions decided altogether: inspection of the height of the toothpick with a small rule made in millimetered paper pasted on Bristol board to get the zero matching the support, accurate reading of the support orientation (mark the North or South direction with the compass), global readings (give the "start" signal), very careful plots (with a well cut black pencil) from the toothpick's bottom until its shadow's end (flat and not pointed as we have seen).

Confrontation of the new results. It will be enough to take off the tracing papers and superimpose them pair by pair making the reference marks in the North direction matched. What a (bad) surprise! Within a few exceptions, the drawings will not match really, either in angles nor in lengths ... The children will look after the causes. After suspecting the lack of rigour of the drawers of especially weird tracing papers, they will examine closely the involved solar sticks and they will claim: "Of course! That toothpick is not absolutely straight! " They will be able to check that making a solar stick oscillated even very slightly on its support will significantly modify the length of its shadow and its orientation. But maybe another solar stick pointed out will not reveal this defect ...

Then, one will have to search another explanation, maybe considering the support: "Well, this board does not seem to be perfectly put flat ... Indeed, a rule was left underneath!" Making this time the support oscillated while keeping the solar stick absolutely straight, the children will note that the shadow of the toothpick immediately starts moving. Hence they will understand that, in order to obtain similar measurements of the shadows, it is necessary that, in addition to all the precautions already taken, all the solar sticks remain straight and that all the supports stay flat.

Actually the real need is that all the solar sticks at the same geographical place are identical and parallel (whatever the inclination is), and that the supports are also all parallel: some additional experiments would show that one can obtain equality of the length of the shadow from solar sticks having an identical height and totally flat supports having the same inclination one to each other. The verticality of the solar sticks and the horizontality of the supports (that the children are now going to strive to get) are in fact a particular case, a pure convention, but very convenient for our project on Eratosthenes' experiment!

4) Using the notion of verticality and horizontality to adjust the gnomons.

Duration : 2 preparatory sessions lasting around 30 minutes ; short moments to adjust the gnomons before later reports.

Location : classroom then location of reports.



Equipment :

For each group of 4 to 5 pupils:

one ordinary set square,
one Bristol board rectangle (for the double square),
one tracing paper sheet,
the small rull made in graph paper,
the water level built up by the children;
a sheet of tracing paper for the new reports.

Taking stock.

The answers to the pre-test will already have provided you with some elements about the knowledge of the children on the notion of verticality and horizontality (let's add here "on location" since your pupils will later see that the parallelism between two vertical lines in two different places on the planet, no longer exists, and as well for horizontal lines).

In function of this report (and of the time that will remain afterwards), you can have the pupils work in an experimental way on verticality and horizontality, but also on the straight angle formed by these two directions : [consult the page on verticality and horizontality](#) (you will also find there how to simply make a plumb line but also a water level, and then how to use them).

The pupils must take the time to manipulate water levels ; if you associate them with set square give you the vertical. After that they understand that the most simple way to adjust the gnomons will be by starting with putting the toothpicks in a straight angle in regard with the stands because, once they are adjusted horizontally, the toothpicks will automatically be vertical!

Setting with squares

Beforehand, a new tracing paper sheet is put on each support. By maintaining their square put (on the edge of its base) on the support and against their solar stick to verify that the latter is correctly fixed, the children realize that the square itself can oscillate more or less on its base during this experiment, and hence agree with a solar stick that would be slightly leaning. Then, they propose to move the square a couple of times around the toothpick to be sure that the latter well agrees every time.

While we are on the subject, a very simple folding permits to obtain a double square which will be absolutely stable, hence allowing a fast and reliable adjustment: the children will build it in a Bristol board rectangle of about 32 x 12 cm, whose base will be perfectly rectilinear to permit a folding "edge on edge".

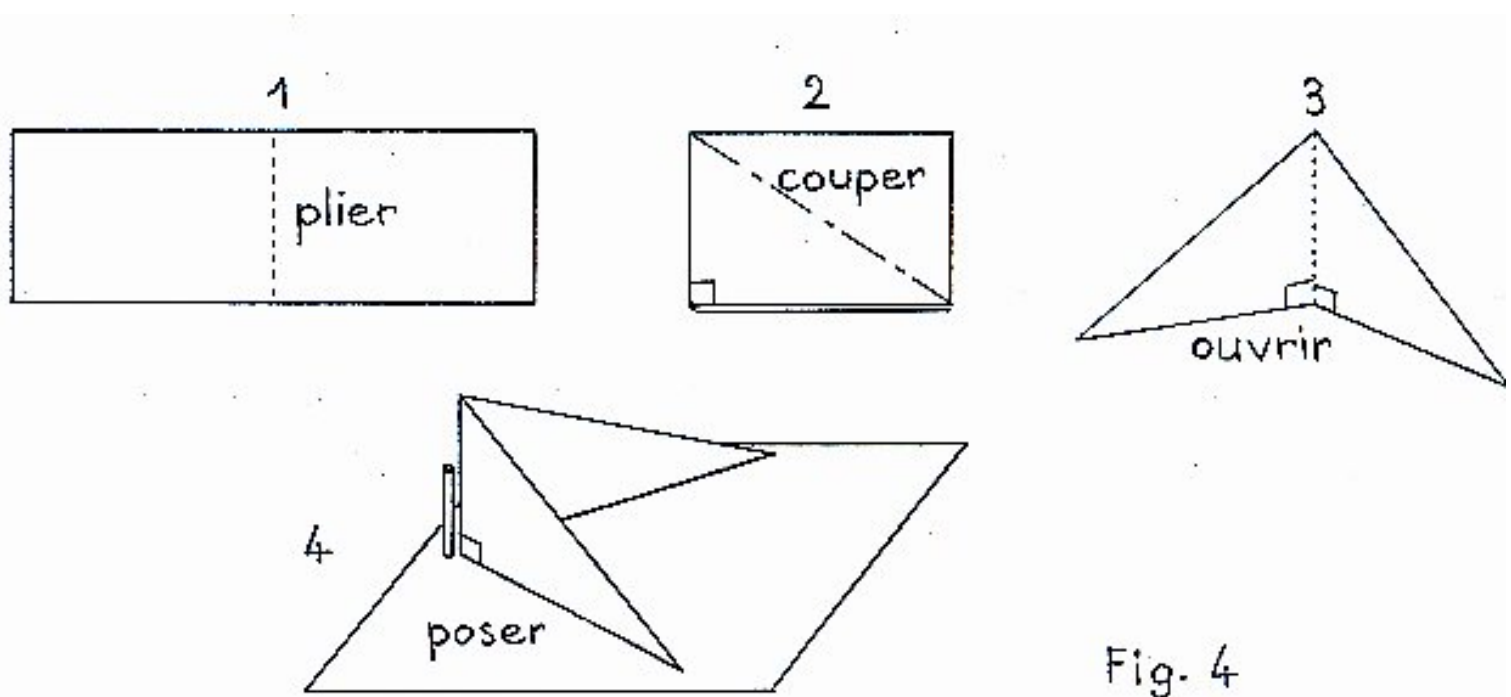

One will also have to think of checking the common height of the toothpicks with the help of small rules made in millimetered paper.

Setting the spirit levels.

Once their solar stick are absolutely perpendicular to their supports, the children will only have to adjust the horizontality of the latters either with a unique water level that they will direct in several ways on the support, either with two levels (totally adjusted together) making an angle very open in front of the solar stick, like the double square.

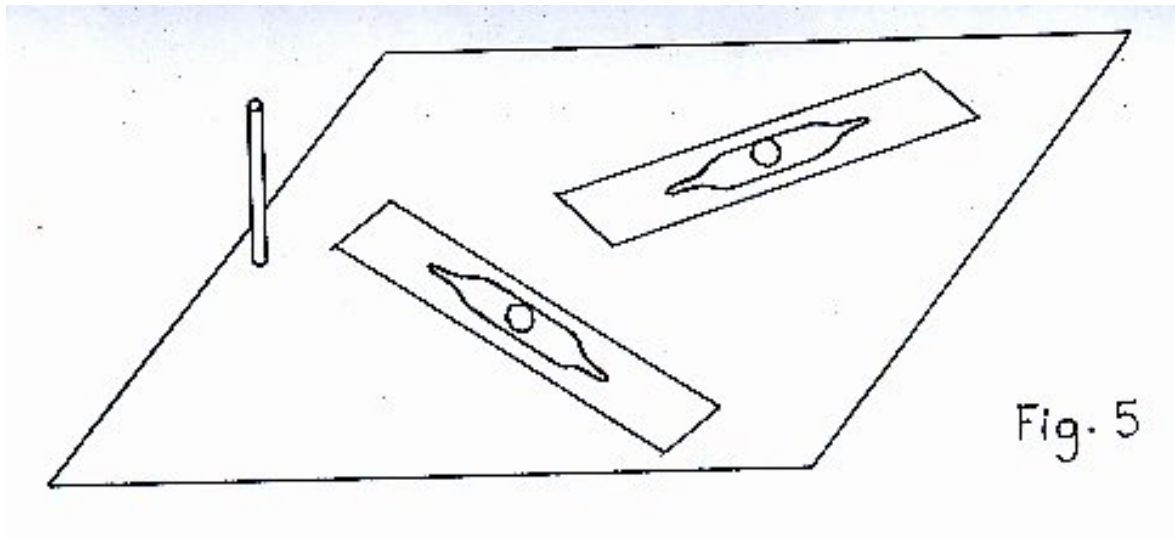

New readings.

Very proud of their well adjusted solar sticks, the children will perform many new readings: let us bet that this time the results will match their expectation, that is to say that they will agree!

Optional sessions (Sequence 2)

Verticality and horizontality

1) Study of the verticality

Duration : a 45 minute session for all the activities described in this slip.

Location : the classroom, the hall or another room and in the schoolyard for a moment, if it is possible.



Equipment

For the class

To build plumb lines:
yarns and various strings (fishing thread),
various small objects that can be hanging,
washers (in two or three different sizes) and
plumbs for fishing.

Preliminary investigation

The pupils share what they know about what is called verticality and especially the objects they think vertical : the tests can be read at that time, and commented.

How can you check the verticality of an object ?

The pupils tell what they know about what we call verticality and give examples of objects that they believe to be vertical: this is an opportunity to consult the test questionnaire and comment it.

How to verify the verticality of an object?

Game-experiment

Perhaps some children will propose to make a simple visual check, not on one isolated object but rather on two different objects supposed to be vertical.

For instance, one can go next to the vertical edge of an open door and one takes a sight on the vertical part of a window on the wall facing at the door by closing an eye. If by slightly nodding one's head one can see the edge and the window coming closer and one can observe that they seem to be little by little parallel until being adjusted all through their length, it is probably because they are both really vertical (or because, by chance, they all bend in the same way either really either by a perspective effect!). It is very interesting to apply this method when one deals with two very high buildings (towers of our modern cities): the accuracy of their verticality is really breathtaking!

Hence the children can enjoy trying to apply this method. When they note that something does not work properly, they must detect which one of the two objects is not vertical (or maybe both!) taking a new sight for each object with respect to a third reference already calibrated (that is to say an object whose verticality has been positively verified).

Building and using plumb lines

After understanding that one absolutely needs to refer to an object which is also vertical, the children may ask: how to check the verticality of an isolated object?

Some children will have seen sophisticated spirit levels whose one of the three bubble tubes allows to check the verticality of an object (the two others indicating of course the horizontality for one and the 45 degree angle for the other). Other pupils will probably have heard about the plumb line. So it will be interesting to build one plumb line from different types of strings and plumbs: one will observe that fine string or fishing thread suits relatively light plumbs better than thick string which becomes taut with difficulty. The metal washers will be especially useful because they can be attached easily and their flatness permits to approach the line to the object to be tested as close as possible.

Once the plumb lines are finished, the pupils will use them to check the verticality of various objects inside the classroom and outside (figure 1).

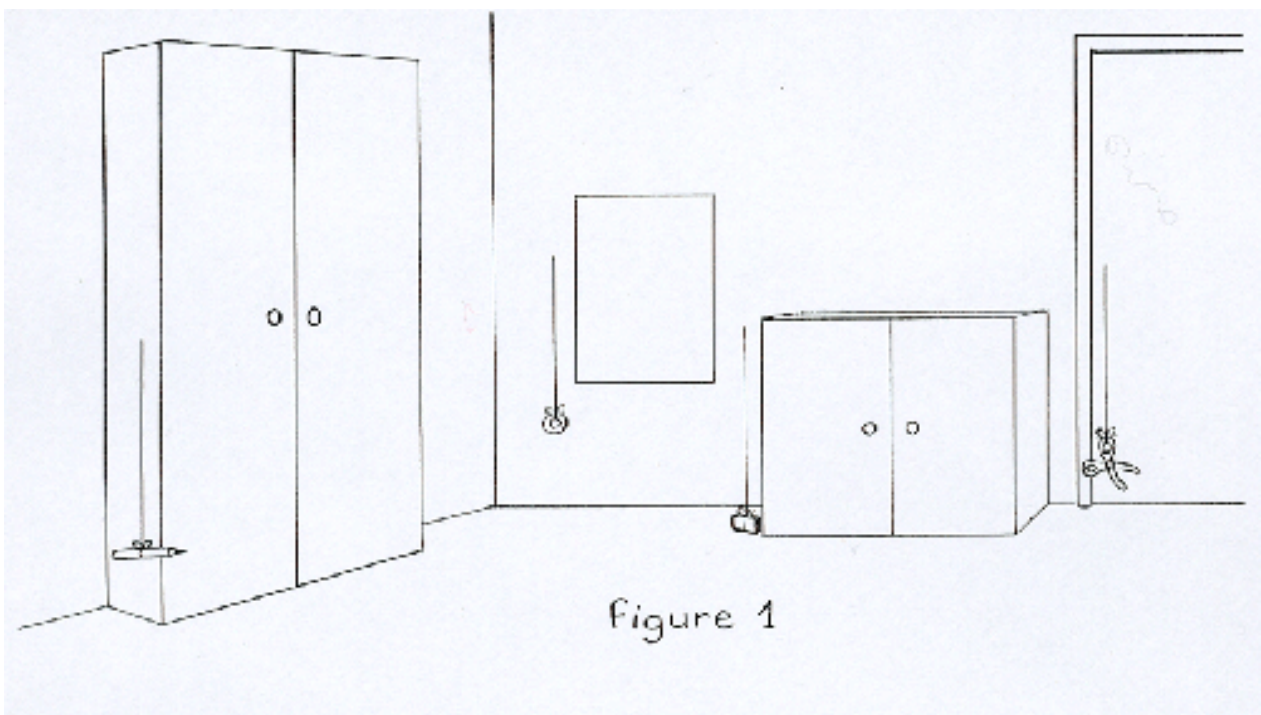

2) Experiment slip on horizontality

Duration : 3 sessions

Location : classroom.



Equipment :

For the class

For the main session (experiment with the containers of water):
8 to 10 large ordinary white paper sheets (50 x 65 cm),
about a dozen plastic containers (see further down which ones) with some water slightly colored (foresee a sponge!),
black pencils,
a few long flat rules or pieces of electric beadings perfectly straight,
a spirit level bought in the shops.

For each group of 2 pupils :

building the spirit levels
one phial of physiological serum (item sold in chemist's shops for babies hygiene),
20 cm of a 40 mm moulding,
adhesive tape..

Preliminary investigation

In general, the children define horizontality by quoting various objects of the daily life like the ground of rooms for instance: "it is always perfectly flat and if it climbs a bit sometimes, one feels it immediately", or the top of a table: "it is flat too and if it is slightly leaning a ball will roll and fall down on the ground". Hence, horizontality is a synonym of stability for them. This is perhaps the reason why they do not think of quoting water at rest, unstable by nature. Ask the pupils to draw a liquid in a container: many will trace a waving line as a surface. And if one asks them to draw a bottle about to pour a liquid in a glass, the liquid level will be definitely leaning.

Experiment

There is a little experiment to discover the horizontality of the free surface of a liquid, the pupils divided into groups of 3 to 5 but using a shared equipment.

Several large paper sheets, re-cut to get an ordinary irregular shape, are posted up on the walls and on the black board, one per group.

About a dozen different transparent (or translucent) plastic containers are put on a central table.

They are containers for deep freezing, small containers for carry-out food, various bottles. Their section is preferentially square, rectangular, or oblong; each of them contains slightly colored water until about a quarter of their height.

One child per group takes one of the containers, brings it near to the wall and "applies" it carefully against one of the sheets, without trying to put it "straight" but rather by slightly leaning it, and keeps it motionless. A fellow draws its contour and, once the water is at rest, he leaves a small mark near the container here and there to locate the liquid level. The operation is done several times with various containers differently leaning.

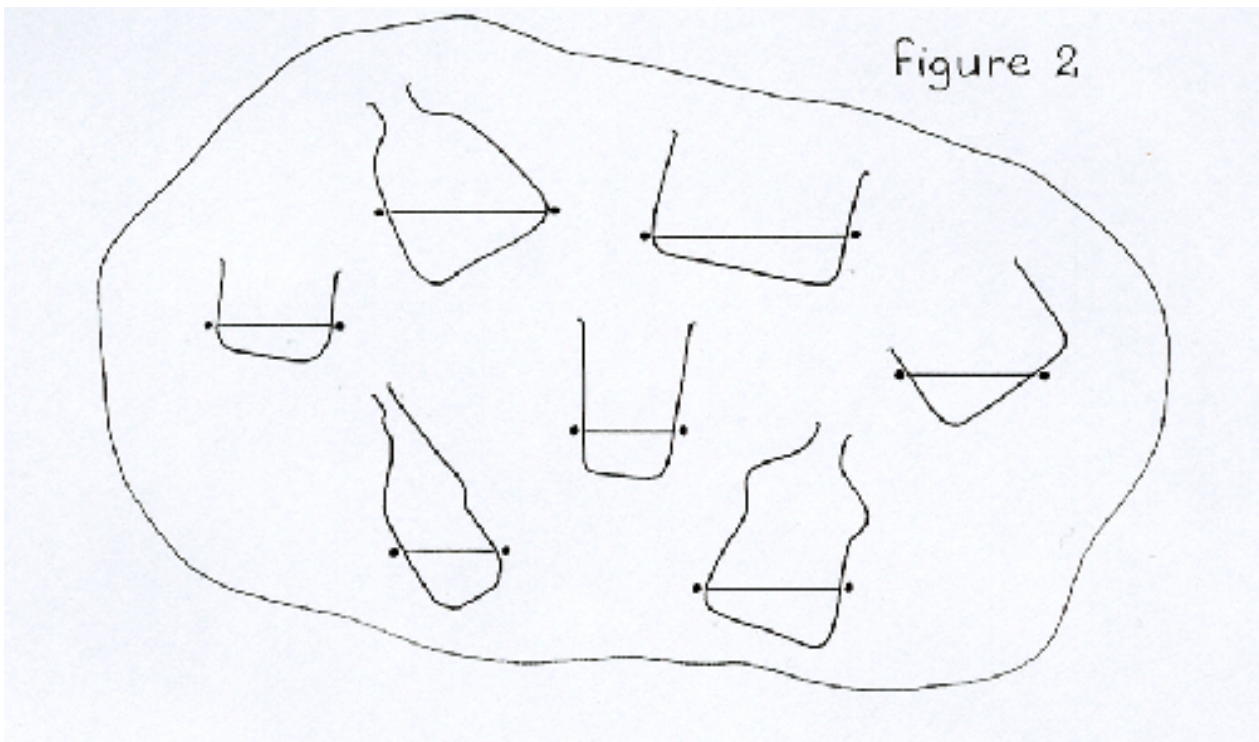

The children realize that "all the marks appear absolutely flat". How to verify it? "One can enlarge them on both sides with a long rule to better see". This brings the note: "The lines are parallel. How to verify this parallelism?" Some will propose to measure the separation of the lines continued at each of their ends.

Thus, to verify that two lines are perfectly parallel, they will continue (carefully and with a long rule) the lines of the water levels until the edge of the sheet posted on the black board. Then they will measure the separation between both ends of those lines. A half a centimeter error being accepted, they will be able to conclude that the lines have the same separation and hence are parallel! (see figure3).

The children whose parents are do-it-yourself enthusiasts will certainly quote the water level and will propose to bring one in class. Once the object will have been observed and tested, it will permit to check on the sheets still posted the horizontality of the lines corresponding to the water levels in the different drawings of containers (figure 3).

The pupils will certainly use spontaneously the spirit level on tables, shelves, benches, and so on, to check their horizontality.

However they will often place it in only one position, usually parallel to one edge: then dare them to obtain the centering of the bubble on a table that you will have leaned before (raising up one foot on a book for instance). They will do it after a few attempts and they will understand that it is necessary to place their spirit levels in at least two very different positions on a given object to be sure of its horizontality.

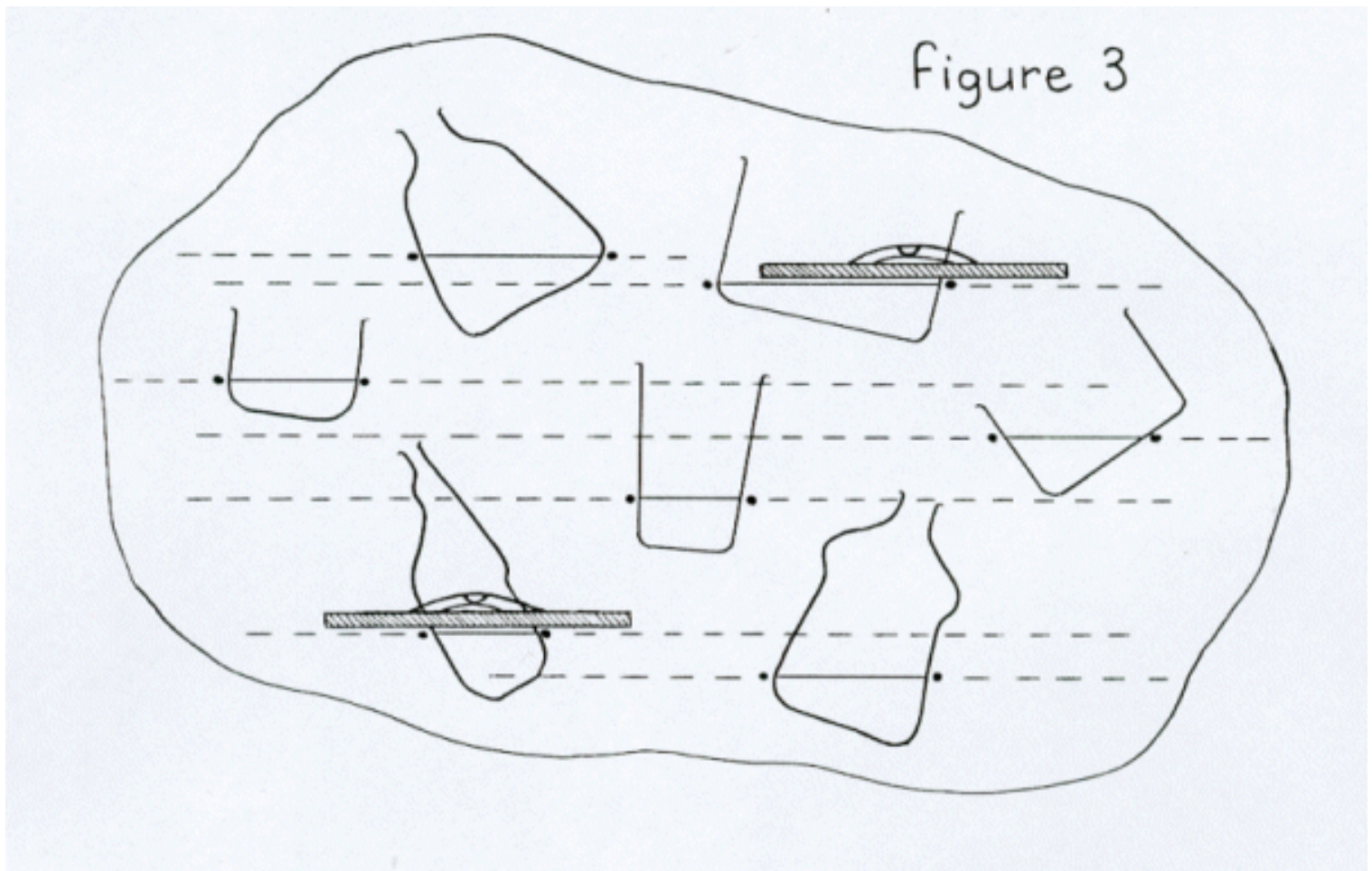

Building and using spirit levels

Here is an easy and quick manner so that the pupils build some spirit levels very smart: from physiological serum phial attached on pieces of 40 mm mouldings, with 20 cm per level. The phial, put flat in the hollow of the moulding, is maintained by adhesive tape. Now one needs to test the whole tool on a surface whose horizontality will have been verified with a "true" level, this in order to possibly modify the phial position on its support with paper chocks. The pupils will adjust the phial so that the bubble stabilizes exactly in the middle. They will see that it is not necessary to put a mark on each side (like in the levels found in the shops whose the tube has slightly the shape of a bridge) because at the smallest leaning the bubble goes back to one of the phial ends.

Hence the children will be able to use the level (or their own level) to settle the support of their solar stick.

Discover experimentally the right angle

The great sheets with the drawings of the vessels containing water being still there, suggest, if your pupils haven't already had the idea, to take the plumb lines and use them next to the drawings to see if there isn't something interesting to discover... *"The plumb line crosses the surface line just like the + of an addition."*

Give a small sheet of coloured paper to each group and ask if it couldn't be inserted in the "crossing". The pupils readily see that the sheet can not only coincide with each of the four sectors of their "crossings", but that also, if they turn it, each of its "corners" would fit (fig. 4). *"We could also put in a crossing four set squares just like my big brother's ! With it, he can draw right angles exactly like those we were asked to point in the test."*

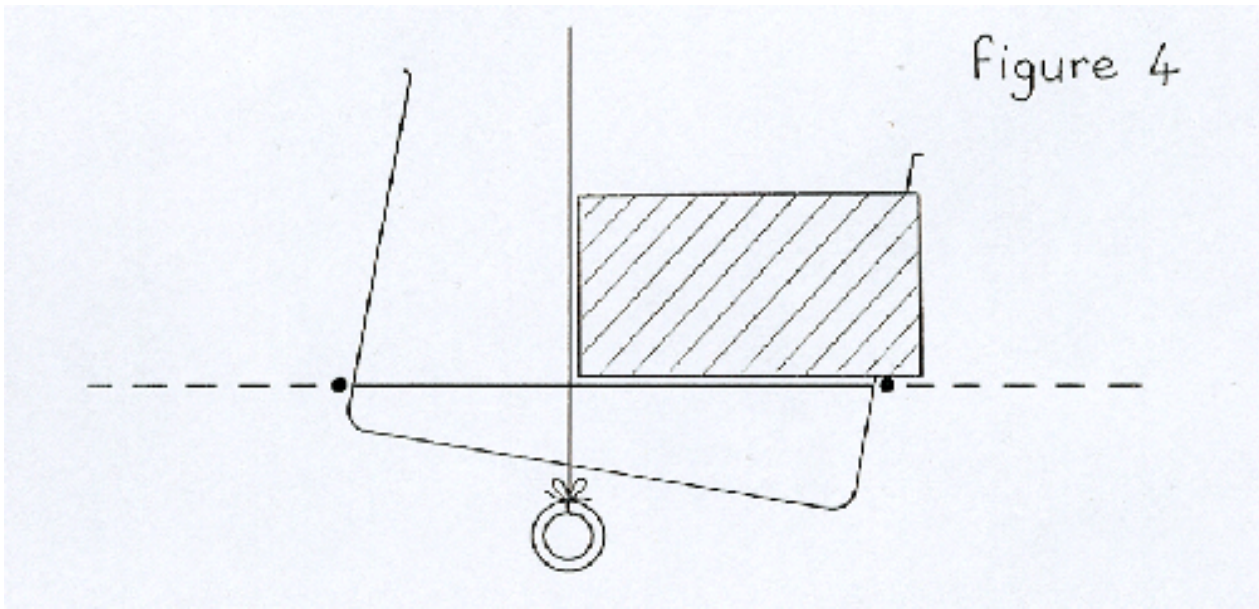

Of course, the pupils will look for objects around them, numerous, that show right angles. They will also try to draw right angles with a set square, and see that they may not need one with graph paper or small square paper (but only when one of the sides of the right angle coincides, or is parallel to a ruling).

So, having discovered what is "*upright*" is vertical and what is "*level*" is horizontal, and that the "*crossing*" of both gives the right angle of the set square, the pupils understand that the gnomons on their support must have these characteristics to be really reliable.

Optional activity (Sequence 2)

Building and using small compasses

This session permits to get the children used to the compasses, useful for the readings of the shadows. Hence the children will be able to focus later on the measurements with the solar sticks in forgetting how to handle this instrument still fascinating!

A few days before the session, you will ask the children who own a compass to bring it with them to the class.

Duration : one half an hour session in the classroom.

Location: classroom.



Equipment

For each group of 3 to 5 pupils:

One small ordinary compass,
The tracing paper with the plots of the shadows,
One black pencil.

In option, to build a
"floating compass":
One big darning needle,
One magnet,
One polystyrene square,
One plastic plate with water (plus a sponge or a
floorcloth!)

Preliminary investigation

Once the children have in hand the magnet, the polystyrene and the plastic plate, they first look for making the magnet floating by putting it on the polystyrene square: it is true that by trying to put it successively on all its sides, especially on the edge sides, the children see at a time that the magnet is rotating and then earnestly orientates itself along a given direction: a template compass (not too close to the plate with the magnet otherwise it would loose its North!) confirms that this orientation is indeed related with the North/South direction. Then one just has to paste the needle on the magnet so that its point shows the North.

However, this assembly is very unstable and depends on the shape of the magnet. Hence one will propose to the children to replace the magnet too heavy by a darning needle one has to magnetize. For this, ask the

children to rub the needle with the magnet. The pupils finally rub it but without knowing exactly how: in fact one must always go in the same direction (no up and down by no means!) and this repeated at least twenty times. In this way one gives to the needle the magnet's magnetism. Next, once the needle is "magnetized", one passes the needle in the slice of the polystyrene square by going through from one side to the other, and the floating compass is ready (fig. 3) !

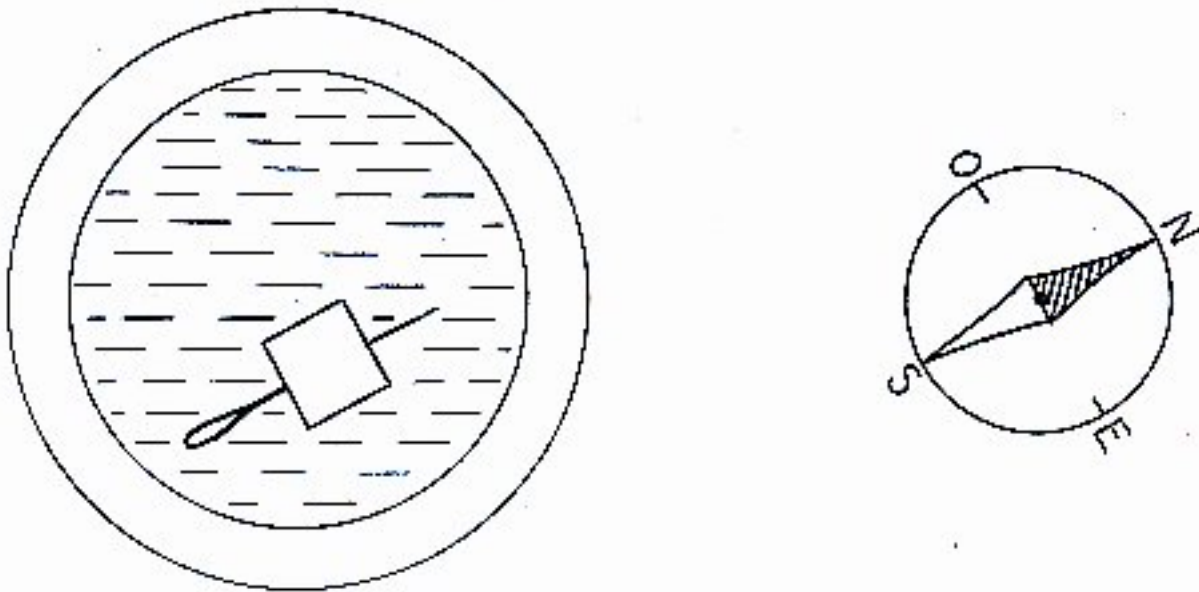

Remark : Your pupils might notice something weird when their magnetized needle is put in the water : some of them will indeed point towards North, but the other ones will point South, the opposite direction... Why is that? It is related to the fact that the two sides of a magnet have an opposite polarity (one is negative whereas the other one is positive). Therefore, if the needles have been rubbed, some with a positive side and the others with the negative side, the latter will have the opposite orientation with regard to the North. This double polarity is easy to mount. Pick two magnets (bare ones if possible), and approach them face to face; according to the faces you show, they can either attract each other (opposite polarities) or repel each other (identical polarities). You can then test this double polarity rubbing some needles with one face and some with the other one, making provisions and checking them afterwards.

Other activities.

You can also add to this approach a study of the four cardinal points and of the intermediate directions (the ones given by a compass card : North-East, North-West, South-East, South-West, but also North-North-East, North-East-East, and so on...)

Then you can suggest activities of orientation during which the pupils will try to define as well as possible the orientation of an element of the landscape (building, gate, tree, hill...) without however trying to evaluate in an angular point of view before having studied the notion of angle and learnt how to use a protractor.

Last, the pupils will learn to locate themselves on a map starting by orienting the map itself in regard with the North given by their compass, and then determining the direction of a place in regard with another one.

Sequence 2

Technical assistance for sequence n° 2

The second sequence suggests you to undertake a daily observation of the course of the Sun in the sky. Its course above our heads is due to the rotation of Earth around its North/South axis every 24 hours. The variation of this course through one year is caused by the angle this axis makes with the plane of Earth's orbit, and the revolving of Earth around the Sun in approximately 365 days. Let's now have a closer look at these concepts.

Rotation of Earth

The alternation of day and night is probably the clearest and most striking of all astronomical phenomena for living beings. The Earth rotates upon herself from West to East in 23 hours and 56 minutes in relation to the most distant stars (almost fixed). In one day, it also revolves around the Sun, little less than one degree, which slightly lengthens the duration of the solar day to approximately 24 hours. This is the length of time it takes for the Sun to cross the meridian twice.

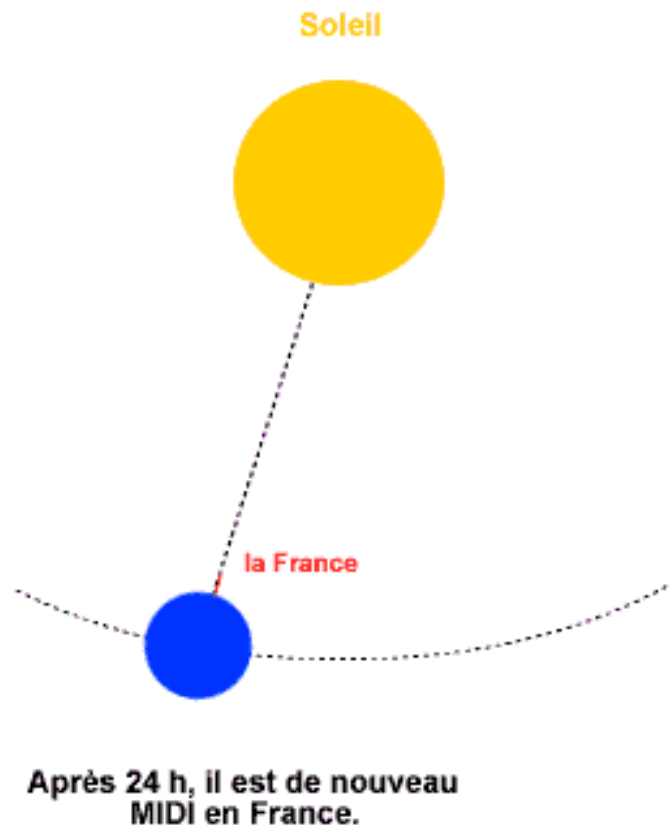

For a long time, we thought that Earth was motionless, at the centre of the universe, and that all the stars were turning around it. Aristarque de Samos (310-230 before Christ) was the one who laid the foundations for our actual cosmology, saying that Earth was revolving around the Sun in one year and rotating upon herself in one day "like a spinning top". His system got to us thanks to the works of his contemporaries (such as Archimedes) and of Greek historians. The Polish Nicolas Copernic (1473-1543), used his theories and was the first to dare a theory where Earth was a planet just like any other, revolutionizing not only astronomy but also the whole

human thought.

The daily course of the Sun in the sky

It is the rotation around the North/South axis that gives us the delusion that the Sun (and the stars) are turning above our heads, in the opposite direction : rising in the east, at its highest at midday to the South (for the northern hemisphere) and finally setting in the west.

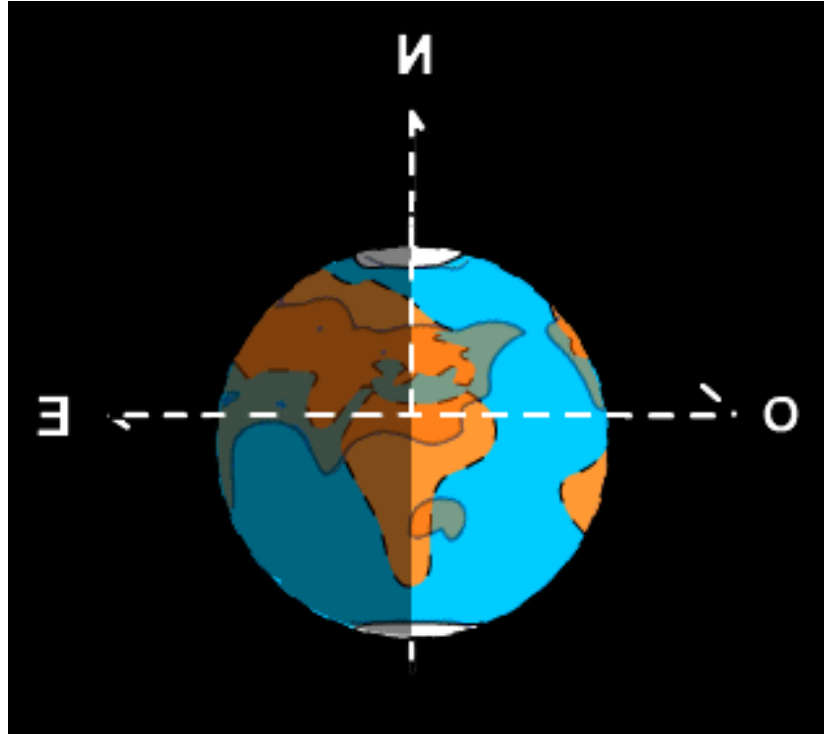

We should draw your attention about the notion of "solar midday". It is the exact time when the Sun is at its highest in the sky, and therefore the time when the shadows it casts are at their shortest. Its course in the sky is exactly symmetrical with regard to its position at solar midday : etymologically, "midday" means the half of the day, of the sunny period. Be careful : this midday is not a clock midday! Furthermore, this moment changes during the year, but we'll see this notion in future sequences.

Preconceptions !

People often believe, wrongly, the Sun rises exactly in the east and sets in the west. It is absolutely true only two days in the year : the days of the equinox (when the day lasts exactly as long as the night). In winter, it rises in the south-east and sets in the south-west, shortening its course in the sky (for the northern hemisphere). In summer, it goes to the north, lengthening the sunny period (of course, the opposite case happens in the southern hemisphere). Where do these variations come from???

Rotation axis inclination

Earth completes a course around the Sun in one year (365.25 j), following a trajectory (called orbit) inscribed in a plane called ecliptic. Just as a spinning top, it glides on a circle (accurately an ellipse) about 150 million kms radius. Its characteristic is that its rotation axis is inclined with regard to the plane of the ecliptic : the axis between the two poles has a 23.5 degrees inclination and always points in the same direction to the stars (the famous "pole star").

The seasons are linked to this inclination, and not to the distance Earth-Sun. So, when the northern hemisphere gets warmer under summer sun, the southern hemisphere gets through the harshness of winter. That's why the

North pole is lit during the whole of summer, and the South pole is in darkness, Earth showing mostly its northern hemisphere to sunrays. The north-south rotation axis always pointing the same way, the reverse situation happens six months later.

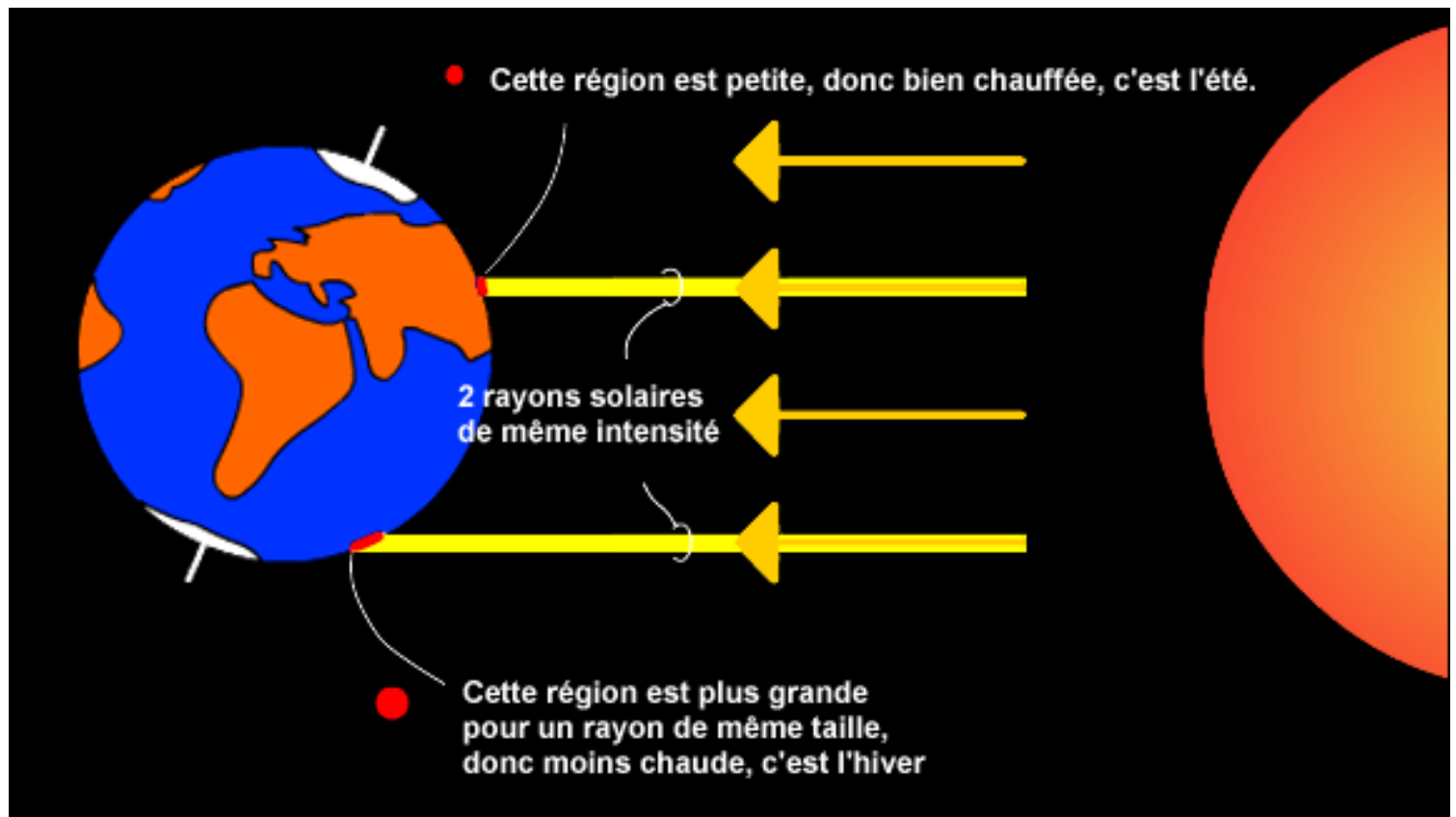

North and South : thake care!

Until now, we have used the geographic north : the direction of the north pole from the point of observation. This north pole is nothing more than the place where the rotation axis passes through Earth. To discover the exact North, we generally use a compass.

How does a compass work?

The use of a compass can raise questions about magnetism, but you will have to be careful in your explanations and only explain a few facts in that difficult field.

The needle of a compass is a magnet with a north and a south pole (the use of the word "pole" is an analogy with Earth). Two magnets can attract or repulse themselves according to their place with regard to the poles, that is why you have to use a compass far from any piece of magnetic material. Non-magnetized iron magnetize when they get close to a magnet (try with nails or needles). A few coins, still in use in 2001, are attracted by a magnet because they are made with nickel. Finally, a coil of electric wire act just like a magnet when power runs in it. (see file n°15 of the ministère de l'éducation nationale, on <http://www.eduscol.education.fr/>)

However, the two magnetic poles (North and South) do not exactly match with the geographic ones. Furthermore, they slowly drift from year to year. You have to compensate with a correction called magnetic variation to the direction shown by the compass in order to find geographic north, correction depending on our place on Earth, as well as the date (this question in the magnetism will not be explained to the pupils).

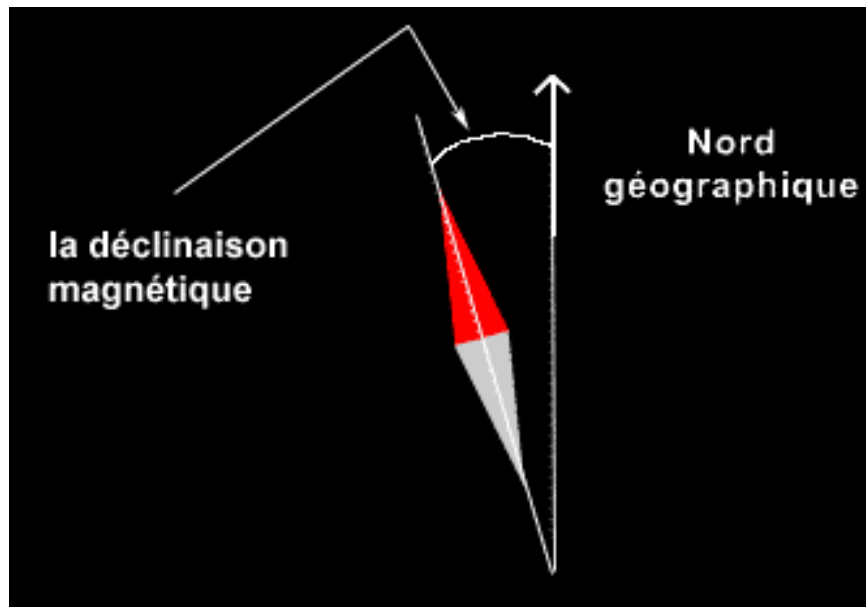

You should know that the North-South direction given by your compass slightly drifts (a few degrees) from the geographic poles, and that you will get a more accurate estimation of their direction with the shadow at solar midday. Enjoy and measure this angle with your pupils!

Sequence 2

Technical assistance for sequence n° 2

Sequence 2 tackles with the notions of the vertical and horizontal. At a small scale, these notions are very intuitive, but at the scale of our planet, more thorough explanations would be needed.

To imagine the vertical and horizontal

The vertical in one point is the direction given by a plumb line. A weight hung at the end of a line tightens it in the vertical direction with regard to the place.

The horizontal is the line on a plane equal to the surface of a liquid at rest : a plane that can be determined with an air level. It is a long bar containing a short glass tube of liquid with a bubble. When the level is horizontal, the bubble is centred in the middle of the glass tube. If it is not, the bubble drifts to one of the extremities.

For each given point, only one vertical and an infinity of horizontals exist. In the schoolyard, every vertical are parallel to each other, and perpendicular to the horizontals. But on the surface of the Earth, the verticals, (as well as the horizontals) are not all parallel one to the other. All of them are related to the centre of the Earth.

To prove it, you could measure the variations of the plumb line :

2 plumb lines 111 km distant from one another (1° latitude) would make an angle of 1° .

2 plumb lines 1 km distant, there would be $1/100$ th degree, or 36 seconds. On the 10 meters of a classroom, it would become 0.36 seconds, a difference much smaller than our protractor could show.

The angle between the verticals can be measured only between very distant points (hundreds of kms).

Everyone know that the Earth is round, but it seems plane to us. How can we reconcile these two views? Our close environment (the streets, the wall of the schoolyard...) are on such a small part of our spherical Earth that it can be deemed as plane.

At the scale of the planet, the vertical to our place is no more than the extension of the line that joins our position on the surface to the centre of the world. So, when we go from one place to another (from Lille to Marseille), the lines change, changing the vertical.

Of course, if the trip is a small one (from one end of the schoolyard to the other), the lines are nearly the same.

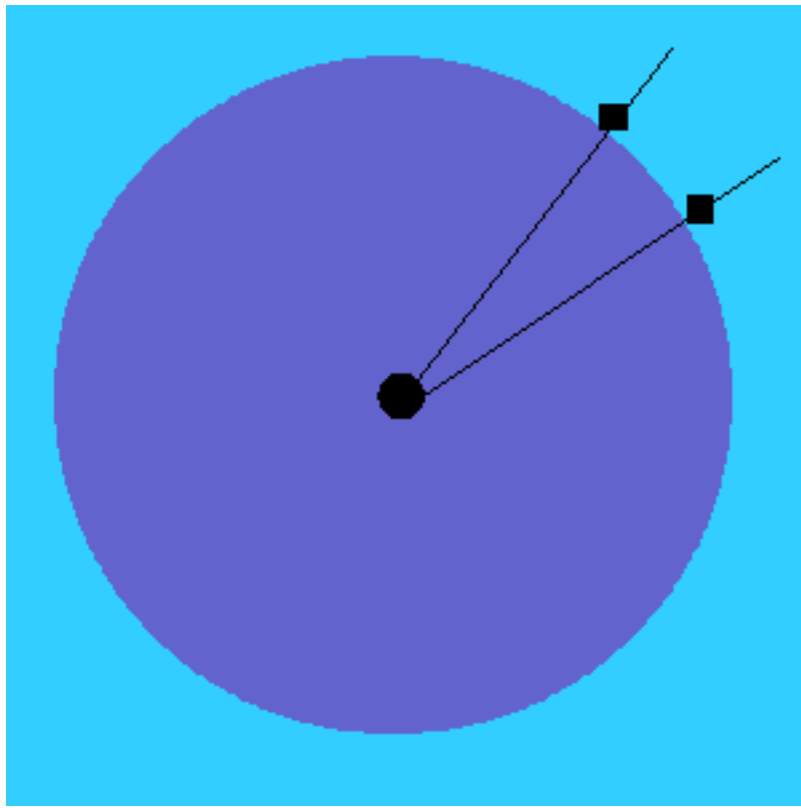

At the scale of our planet, the horizontal is locally contained in the plane tangent to the surface of the Earth (spherical). For short distances, these tangential planes merge and two horizontal planks placed at the two ends of your classroom will not seem inclined one to the other. Not because the angle between these two planks is nil, but because it is too small for you to measure! remember that the Earth's radius is approximately 6370 km, and as such you'd need great horizontal dimensions (at least a few dozens of kms) in order to see the curve (the horizon at sea, for example).

What are the vertical and horizontal?

What is the common "denominator" we could use to understand the physical nature of these two notions? Gravitation, of course! The gravitation attracts the weight used to tighten the plumb line. It also attracts the water and makes its surface horizontal.

What gravitation is precisely?

We could describe it as a characteristic of matter : "matter attracts matter". Two bodies attract each other, all the more they are massive and the distance between them is small. For example, if you drop a lump of chalk, it falls on the ground. Why? Because the Earth and the chalk attract themselves mutually.

Where?

In fact, each particle of which the Earth is made attract the chalk, but because of its spherical shape (also for reasons of homogeneity as well as distribution of the mass in the successive layers that make the inner structure of the Earth), and you can deem that the Earth's mass is concentrated on its mass centre (that can be taken in first estimate as the centre of the Earth). The attraction of the Earth on the chalk will then be directed towards the centre of the Earth. That is why the plumb line is directed towards the centre of the Earth and materialize the vertical in one point : it stretches towards the "centre of the Earth's masses".

Consequently, if you drop the chalk without casting it, the lump will also follow the vertical!

What about the horizontal?

The same happens with all the particles of a body of water : they are all attracted to the centre of the Earth. At rest, all the parts of the surface of a vessel full of water will be at the same distance from the centre of the Earth. That is why the surface of a liquid in a vessel is parallel to the surface of the Earth : at our scale, it draws a horizontal plane, and at the scale of the planet, it matches the curve of the Earth. Locally, the surface of the ocean (without the waves!) is plane, but at the global scale, it is a sphere.

Further...

Does the vertical really go through the centre of the Earth? The answer would be yes if the Earth was really a perfect sphere and if the masses of which it is made were absolutely symmetrical with regard to the centre of this sphere. More accurately, it is slightly plane to the poles. It is just as if the Earth was surrounded with a "roll" around the equator. This morphological asymmetry creates a small deviation in the resulting forces of gravitation acting on the plumb line. Consequently, the plumb line is slightly attracted towards the equator and does not precisely point towards the centre of the Earth, but towards the "centre of masses" that make up our planet.

Sequence 3

To discover solar midday

Introduction

During this sequence, the pupils will have to determine the exact time of this mysterious solar midday, then reproduce it with a lamp simulating the course of the Sun above their gnomon. Afterwards, by lighting this time two small gnomons stuck to a balloon, they will discover again the observations Eratosthene made at solar midday in Alexandria and Syrene.

It must be said that solar midday is the specific time when the Sun is at the midway of its daily course in the sky, the highest point above the southern horizon (or northern, depending on the geographic position, see below). The shadows are then at their minimum length, and directed to the north (or south) : it must be said that we mean by north (or south), the geographic north (or south), so the North Pole, which is slightly different from the magnetic north (or south) given by a compass. If your pupils can't see the difference during their tests, " north " will mean either of the two directions. It must be said also that places on the same longitude (placed on the same meridian) see the Sun culminate at the same time in the sky.

Note : for the northern hemisphere above the Tropic of Cancer, the shadows at solar midday are directed to the north during the whole year. It is the opposite in the southern hemisphere, for places under the Tropic of Capricorn : the shadows point to the south. And for places of the inter-tropical area, the question becomes more difficult, because they see the Sun cross the zenith during the year : depending on their situation, the shadows look to the north during six months, and then to the south during the other six months. In order to simplify, we decided to situate our typical pupils above the Tropic of Cancer. Schools under the tropic of Capricorn, and the ones in the inter-tropical area will simply " translate " north by south, in order to understand the example.

Interest

Course of the Sun. Evolution of its height from month to month. The concept of solar midday. Earth's rotation. Basic concepts of meridian line.

How to begin : what about solar midday ?

We have seen in the last exercise that the pupils have already been confronted to the concept of solar midday, when observing the shadow of their gnomon change from hour to hour. The shadow turned slowly, shortening progressively and then growing in the afternoon. Their drawings opened as a fan to the north, a direction the shadow crossed at some point, undefined for the moment.

Give this text to your pupils, in order to arouse their interest :

A long time ago, even before Eratosthene, man watched the evolutions of the shadow of a stick or an obelisk, in order to follow the course of the Sun during the day, but also during the year. In fact, with the use of small lines drawn to the point of the shadow, it could be used as a watch during the day, and as a calendar from season to season... But the most interesting was that, at a very precise moment of the day, the shadow could be used as a watch as well as a calendar at the same time ! It was at its minimum size. This moment is called solar midday : everyone watched for it, Eratosthene to make his own measurements, but also caravaneers and even pyramid builders for another reason you will discover when you find this mysterious solar midday...

Making use of the remarks and discussions raising from the text, you will make the pupils understand that the first priority will be to discover what is solar midday. Another observation will provide the information needed and will explain some elements in the text, either immediately, or later in the year, after 2 or 3 other surveys..

Sequence summary :

1) Discovery of solar midday with a second survey

2) Use of shadow as " watch " and then as " calendar "

3) Simulation of the course of the Sun, and its height at solar midday

4) Simulation of solar midday with a balloon

1) Discovery of solar midday with a second survey

Duration : Punctual activity made every hour if possible during a bright day, and at more frequent times during lunch time.

Location : Some place exposed to the Sun during the whole day.



Equipment :

for each group of 3 to 5 pupils

1 gnomon of the identical gnomons type (see [sequence 2, part 3](#)),

and the equipment needed to calibrate it ([sequence 2, part 4](#)).

A compass, a pair of compasses, 1 ruler,

1 small ruler made with graph paper,

1 sheet of tracing paper.

Discussions about solar midday.

During the first survey, the pupils saw that " midday " (12 o'clock) meant nothing significant for the shadow, for it was still shortening afterwards, showing no specific direction at that time. But now, they will be curious to see exactly when the shadow will show the north, and when it will be at its shortest : they will write their hypothesis in their notebook. At the end of the discussions, the pupils will be convinced that the only way to know for sure is to put the gnomons back under the Sun...

Prepare for the " hunt " of solar midday.

Everyone agrees that the readings must be made at very regular intervals during the estimated time of solar midday. As this time is the time of midday break, the teacher can hope that most of his pupils will have lunch at school ! (They will try to take turns, in order not to disturb the sitting). During this period, each group of 3 to 5 children will be autonomous, and will choose when to begin and when to make their survey.

In order to find the best time to watch the shadow pointing to the compass north, and the time it is at its shortest, make your pupils draw upon a sheet (placed under the tracing paper) a half circle with their pair of compasses, with a radius approximately similar to the length of the shortest shadow obtained during the prior survey. The sheet will then be centered at the base of the toothpick, from which they will draw a line cutting the half circle in two halves, pointing to the compass north (see fig 1a). Then, the pupils will be able to see at the same time the changes in the length of the shadow, compared to the half-circle, and where they point, compared to the line (which should also be seen on the tracing paper).

Fig. 1

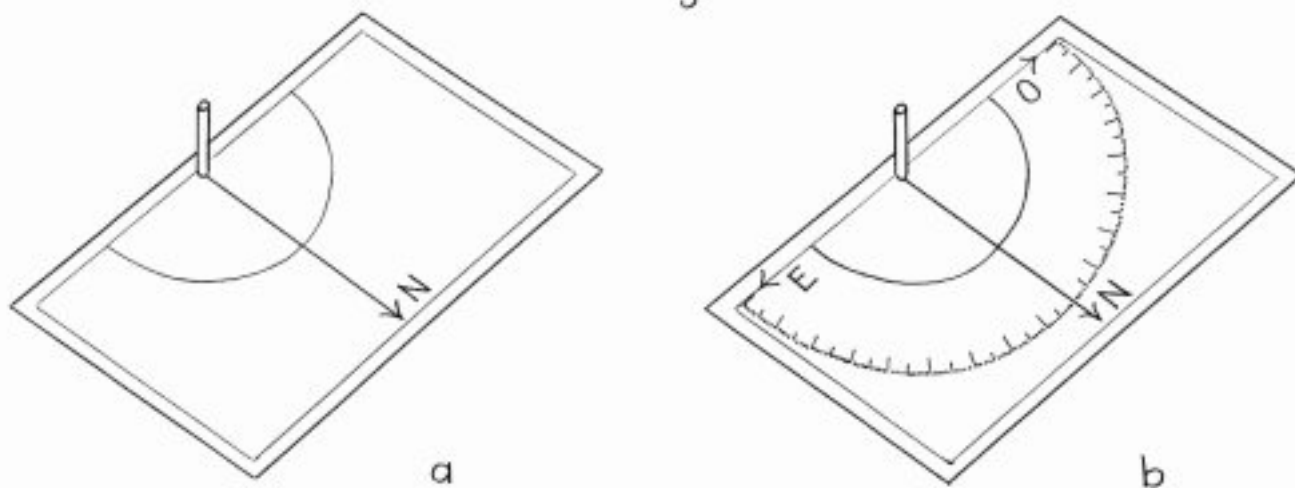

If your pupils are really thrilled by this survey, they will be able, if they calculate precisely the length of the shadow at every measure made, to give an estimate of its angle regarding the north (or east or west for morning and afternoon readings). They could do it by enlarging a protractor with a photocopier, and keeping only the external graduated arc, without the figures. This arc will be enlarged, to put it on an A4 sheet of paper for example, the degrees will be put at approximate intervals of 2 mm, giving a one-third-degree accuracy.

Measurements.

In order to solve the mystery of " watch-shadow " and " calendar-shadow " at the same time, , the pupils will understand that it is necessary to make readings every hour, and then closer ones during midday interclass. In order not to disturb class life, every group will proceed at the same time, on the dot of each hour. But, if this becomes too restricting, it is possible to resume the rhythm of the former survey ([see sequence 2, part 1](#)), and write down precisely the time (hour and minutes) of each reading.

At the first bright day, after the gnomons have been calibrated, point carefully your line on the tracing paper to the north and write down the date. The pupils will make their shadow-readings every hour in the morning, including midday. Some will want to calculate the angle of these drawings compared to the west and deduce Sun's orientation.

Then, each group will take its turn during the interclass -after they all set their watch. They will write

down their readings according to the chosen frequency, without forgetting 1 PM on the dot. Each time, the hour and the length of the shadow will be drawn on the graph paper, and maybe the difference in degrees with the north, and of course the time when the shadow falls upon the line. The readings will then be resumed at each hour until 4 or 5 PM.

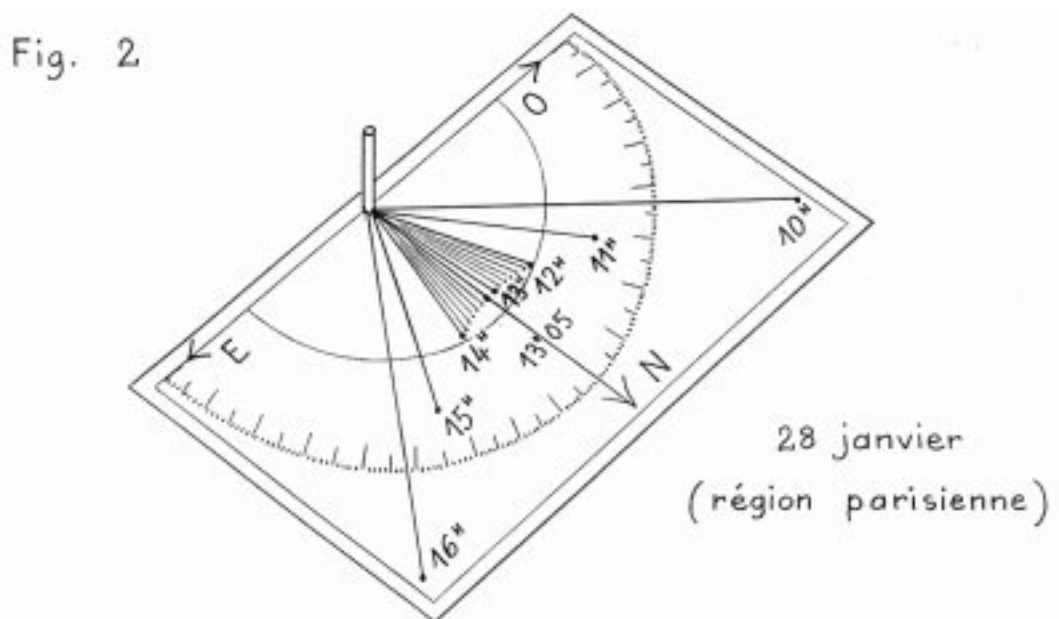

How to read the interclass survey.

As soon as the lessons begin in the afternoon, and so precisely after the probable time of solar midday, the classroom will analyze the tracing papers (and put them back on their gnomons for the end of the survey).

Each group has already seen that the length of the shadow did not change much about the line pointed to the north, and that the slight blur at the end of the shadow prevented precise comparisons. Nevertheless, everybody is now sure that the time when the shadow was at its shortest is very close to the time when the shadow crosses the north line, even if it is not absolutely accurate. How can they be sure, then ?

Each group made its survey at a different time during the probable solar midday time. By superimposing two or three tracing papers will give a better reading of the period, and it will become possible to find the "shortest" shadow. And they will see that the shortest is also the closest to the line.

But it is possible that the most careful readings show a slight difference between this shadow and the north : you will have to explain, then, that compass north is not the " real " north given by the shadow, the geographic north giving the North Pole, and that it is possible to find this direction as will be explained later (see "[how to draw a meridian](#)" at the end).

Confirm the discovery of solar midday.

Ask then how to describe the position of the Sun at that time : they will probably answer " Sun is at its highest in the sky, and right to the south (or north, see above) ". It is a good definition for this mysterious solar midday, the fundamental key in Eratosthene's experiment.

Write on the blackboard the time found. The pupils will ask why their watch doesn't give them the same midday. Explain then that it is for practical reasons that man does not live anymore with Sun's time, and that they will understand with another simulation (see end of sequence).

At the end of this day, make copies of the tracing paper showing the solar midday and give them to your pupils, so that they can stick it into their notebooks : they will outline in color the good shadow and the time of the reading, then discuss the results. They will understand afterwards that solar midday's time at the watch changes from week to week, plus or minus 20 minutes approximately (plus one hour if the country is an adept of summer hour).

We will see, at the end of this sequence, how to determine precisely this hour everywhere and everyday, in a fast and easy way. In France, it is about 1 PM in winter and 2 PM in summer (because of summer hour). But more to the east, this will come half an hour sooner, and more to the west nearly 20 minutes later.

Using shadow as a " watch ", then as a calendar

Duration : The day after the previous survey (or 8 days after at most). Punctual observation made every hour if possible during a bright day, then repeated survey during the year.

Location : Some place exposed to the Sun during the whole day.



Equipment

For each group of 3 to 5 pupils

1 gnomon of the identical gnomons type (see [sequence 2, part 3](#)), and the equipment needed to calibrate an direct it ([sequence 2, part 4](#)).

The previous tracing papers, and one more - blank.

During the days and weeks that follow, as we progress on the project, the pupils will understand more and more of the small text given in the beginning of the sequence. We'll see later that the simulations described later will become deeper and more accurate.

The shadow as a " watch ".

If it is still sunny on the day after the great discovery (or let's hope it will be during one of the eight following days), the pupils will put back their gnomons under the Sun, with the sheet of their last readings. They already think, for most of them, that the shadow will get back a the right hour upon the right outline, and the second survey will comfort them : " The shadow turns, just like the hands of a watch : it gives the hour in the day ". (You can show them that shadow turns clockwise : would it be the reason we used that way for our first clocks ?) Then, ask the shadow could be used each day, then week after : the pupils will write down their hypothesis and argument in their notebook. The experiment will be made later, and that will help the children understand how the shadow could be used as a " calendar ".

The shadow as a " calendar ".

Ideally, you could try repeated surveys at different times in the year, in order to study the different drawings of the shadow's course. See the optional file : "[solar calendar](#)" made with different shadow

layouts.

If you cannot, after having made a few surveys at the time of solar midday, your pupils will compare their different measures and see that shadow's length changes from day to day (shortening from the 21st of December to the 21st of June and lengthening afterwards, up to the 21st of December again) : they will understand then why from one season to the other this shadow can be used as a calendar.

Furthermore, a very accurate survey at the exact solar midday can show a slight difference in the drawings from one week to the other, showing that, compared to a typical watch, solar midday is not exactly at the time it was eight days before. Other surveys will show that this difference can be recorded during the whole year, the time of solar midday changing regularly, compared to " official " time. This is because " official " time do not count some irregularities in Earth's movement caused by the fact that poles' axis is not perpendicular to the plane of our course around the Sun, and that this course is not circular, but slightly elliptic.

At the end of these experiments, the pupils will be able to understand the most difficult points in their text : they know why the marks of a stick's shadow can give for a few days a fairly accurate time, but also why the fact that this time will not be valid during the whole year can help to keep track of the seasons. They will understand, also, why the shadow at the time of solar midday can be of both uses during the weeks, since its length changes. And they will have seen, of course, as soon as their discovery of solar midday, another interest of this shadow for " caravaneers and pyramid builders " : the north will help the first ones to orient themselves during their course, and the others will be able to orient their buildings. If they make a study on Egyptian pyramids, the pupils will see that their ground, a square, is precisely oriented regarding the cardinal points, each side being made to look right towards one of the four directions. The most curious will see that some pyramids are surrounded by a rectangular east-west wall, and that the famous sphinx in Gizeh is looking right to the east, where raises Amon-Râ, the Sun-god, where are built the tombs and funerary temples.

3) Simulation of Sun's course at its height at the time of solar midday

Duration : 30 to 40 min (without the drawings)

Location : Classroom, slightly dark (or any other place)



Equipment :

For each group of 3 to 5 pupils

The gnomon used for the discovery of solar midday,
the tracing paper showing this specific survey,
a great sheet of white paper,
a pocket light.

This experiment will interest passionately your pupils (some may even have already tried it). They will have to reproduce with a lamp the course of the Sun, with a drawing made during the day they discovered solar midday. Each group will put the drawing on the base of the gnomon, and the gnomon on a table.

Reproduce the track of the shadow.

One after the other, by lighting the gnomon with a torchlight, the children will try to make the shadow of the gnomon glide upon the different drawings, according to its direction and length. Their comrades will watch carefully the lamp's movement in both of the aspects : rotation in the " back " of the gnomon and change of height, at its highest at the time of solar midday (cheered as it should be). With trials and errors at the beginning and a slight stop upon each mark, the pupils will finally be able to use their lamp in a fluid and continuous motion.

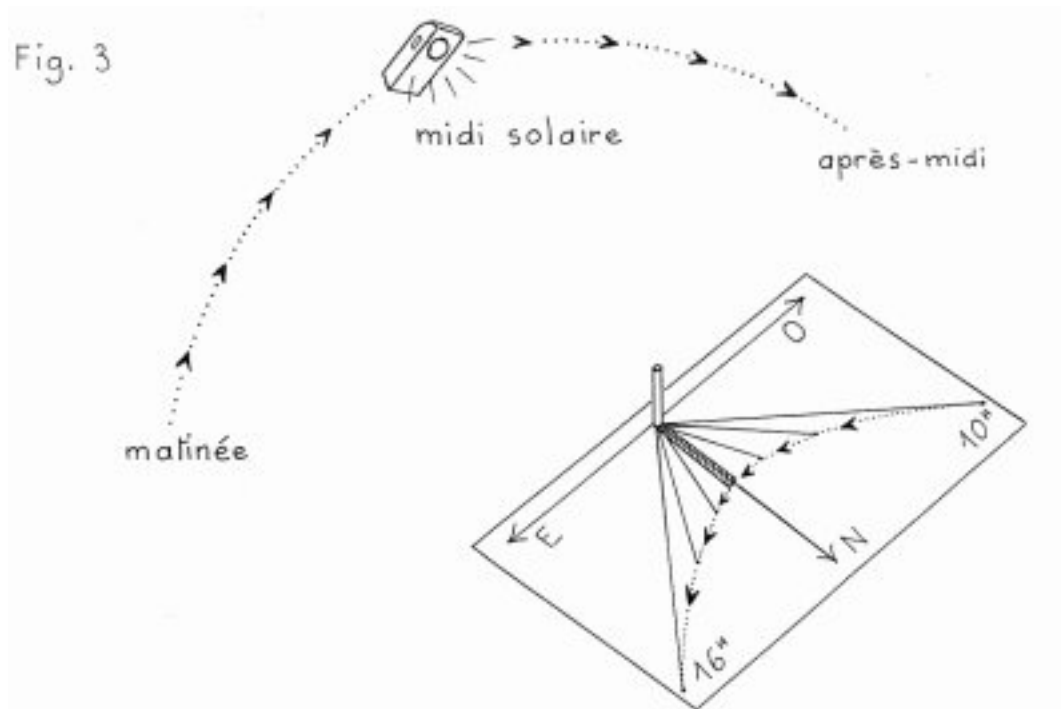

Simulation of the course of the Sun from sunrise to sundown.

You can then ask the pupils to deduce from their drawings on the tracing paper the complete course of the Sun in the sky from dawn till dusk, and then simulate it. Some will spontaneously try to continue the movement of their light, and others will analyze the length and direction of the drawings, trying to deduce those before and after : they can feel then the need to link the ends of the existing drawings and continue both sides of the curve. They will need a large sheet of white paper to put under their tracing paper, then continue the curve right and left of the fan. They will use their light to draw at the point of the shadow the course of the shadow : those who succeed in a continuous movement can boast that they " copied the real Sun ! "

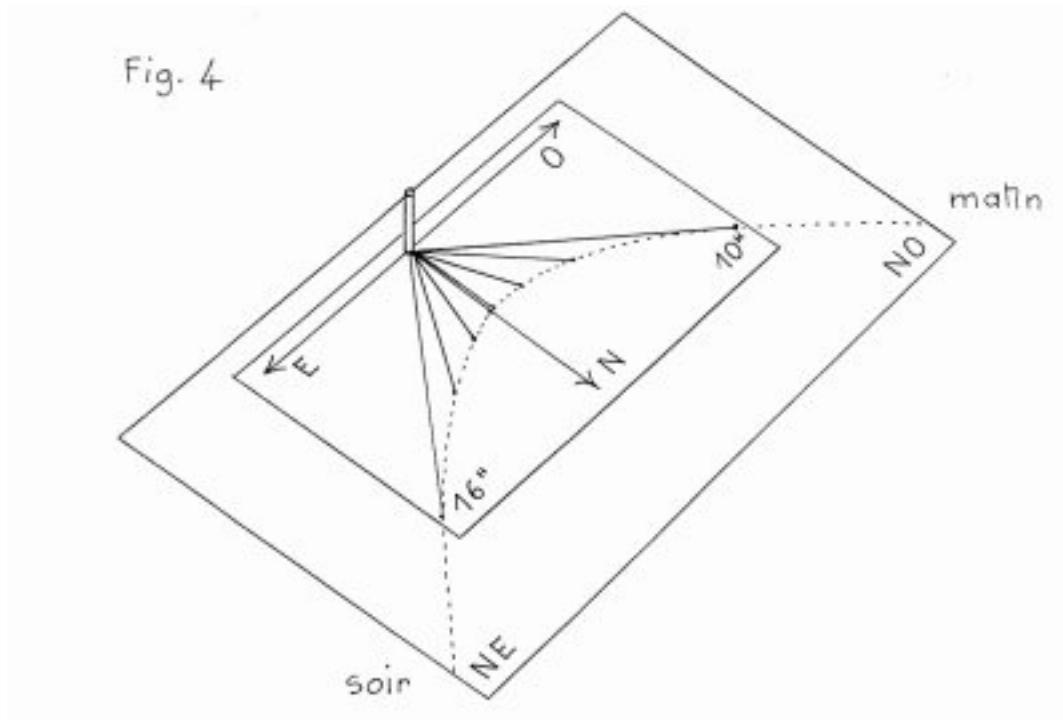

You can then ask them to define, from this curve, an idea of where the Sun rises and sets. Later on, if new simulations are made after new surveys, the pupils will understand that these directions also change : after winter solstice where it rises to the north-east, the Sun rises more and more to the east, being easternmost at spring equinox. Then, it rises more and more to the south-east until summer solstice, and back till winter solstice.

How to sketch the simulation

After a few trials, the pupils will understand that it is difficult to draw efficiently this simulation without using some effects of perspective, which is not really easy for most of them. You can give them copies of the gnomon (the toothpick), the two curves in dotlines and the four corners of the base. (Fig. 5a). From what is shown on their tracing paper, the pupils will have to complete the whole sketch. But, in order not to spoil the central part, they will only draw the three major beams and their shadow. (Fig. 5b).

Fig. 5

(schéma à compléter)

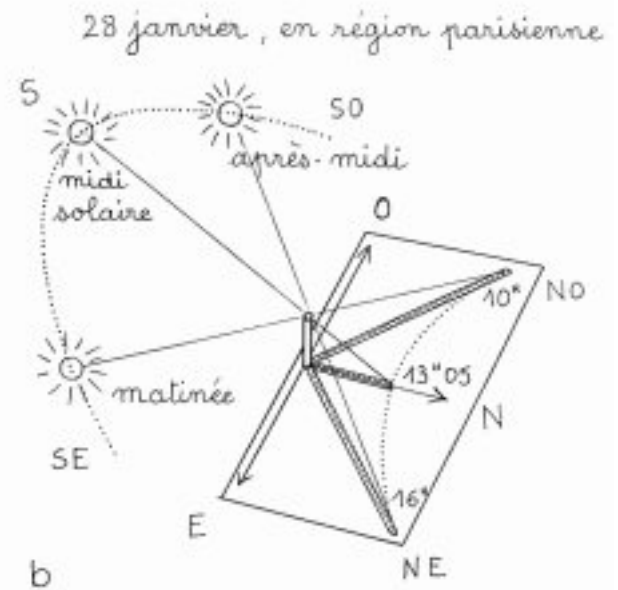
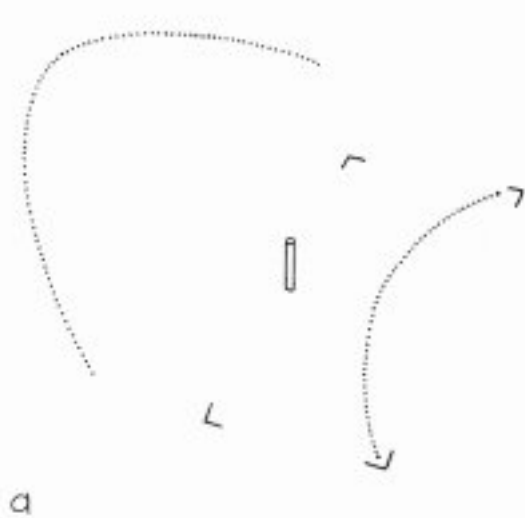

To continue further, you can see the optional experiment : "[how to simulate seasonal variations of a gnomon's shadow](#)".

4) How to simulate the solar midday with a balloon.

Duration : Two session of about 30 minutes each (without writing).

Location : Classroom, slightly dark (or any other place).



Equipment

For each group of 3 to 5 pupils

1st session : a balloon not too small (smooth and plain if possible), a Bristol cylinder wider than higher to put the balloon ; 5 to 6 identical " mini-gnomons ", no higher than 1 cm (tapestry nails, seeds, small screw, bits of matches or small sticks of modeling clay) ; sticking gum ; a torchlight.

2nd session : same equipment, plus a small map of Egypt (reduced with a copier) : the distance Alexandria-Syrene will be approximately $\frac{1}{7}$ th of balloon's circumference (measured with a string), which is purposely bigger than on a globe ; the mini map will be cut in order to keep only the interesting part : the delta and the Nile valley to Syrene

If your pupils were interested by the former simulation, the following ones will be even more interesting for them. They will survey, from " space ", the effects of the rotation of an " Earth-balloon " upon itself, on which have been put " mini-gnomons ", lit by a motionless " Sun-lamp ". The conditions are opposite to the ones of the previous simulations, where the " Sun-lamp " was in motion and the " Earth " was still and plane.

First session

a) How to get the same observations made with the gnomon under the Sun.

Each group places a " mini-gnomon " (a small screw for example) on the balloon, puts the balloon on the cylinder, the whole thing on a table and, to stabilize the cylinder, fixes it with four points of modeling clay around its base. Challenge them to reproduce, with the motionless lamp lighting the screw on the rotating balloon, the movement and changes in length of the shadow seen the other day with the gnomon in the Sun.

Several problems will arise -very interesting- : where must be the lamp in relation to the balloon ? How will the balloon be turned ? How to locate the time of solar midday ? What is to be done if, at that time, the shadow is too long or too short for the screw ? Numerous occasions of debates and trials ! But the pupils will finally solve all these problems and will see the shadow of their tiny screw act like that of their gnomon " with the real Sun ". To do that, they would have to understand numerous concepts, especially that the balloon should turn " the other way of the shadows ", so anti-clockwise.

Fig. 6

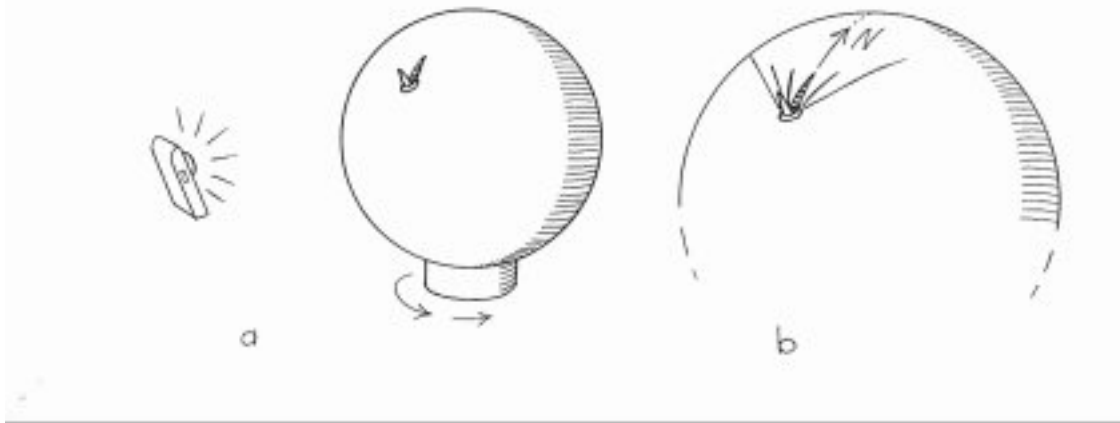

In some groups, the detail of the shadow screw will have been drawn, and it is even possible that they had the excellent idea to materialize the direction of the North pole by an arrow going up to the top of the balloon (see below). All the children will have, of course, observed the two faces of the balloon : the " day " side and the " night " side, and the way the screw crossed the lines of " morning " and " evening " .

b) place several " mini-gnomons " so tat their solar midday will happen at the same time.

Here, your pupils will make an experimental approach of the notion of meridian.

Upon each of the balloons, the screw being in " solar midday " in front of the lamp lit, challenge them again : " Take a second screw and, without having to turn the balloon or moving the lamp, discover where you could place it so that it doesn't have any shadow. Add then two or three other screws for them to be also in solar midday. Then, turn the balloon to check your result " .

The pupils can understand that the second screw will be the equivalent of the staff in Syrene, the first being the one in Alexandria. So, they will easily find its place to the " south " of the first one. The ones who had the idea to draw their line up to the north pole of the balloon will see immediately that the second screw must be placed somewhere on the continuation of this line. Then, they will easily find a place where to put the other screws, linked in the same fashion, and discover interesting things for the continuation of the project : that the shadows coincide with the line, that their length grow progressively towards the " poles " , and that the screws " south " of the second see their shadow pointing towards the " south pole " .

Fig. 7

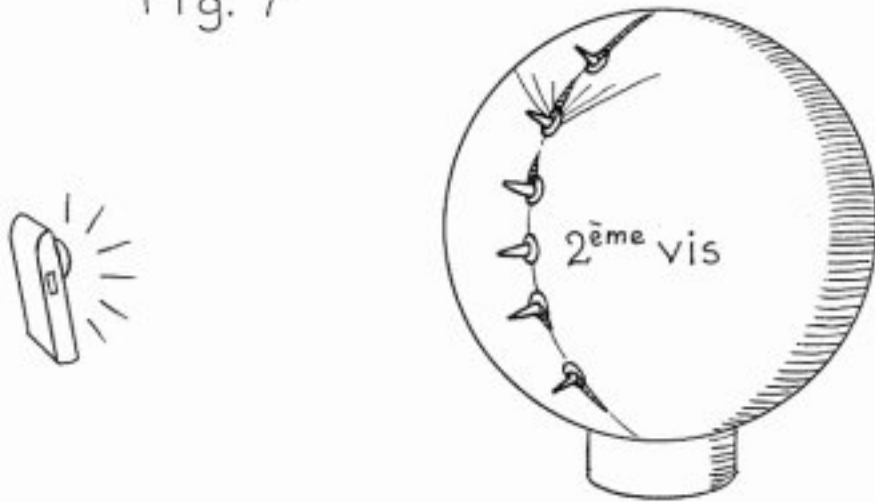

You can then ask what could do the line upon which are stuck the screws if it was continued both sides. " It will go all around the balloon ! ". The pupils will then predict that if they put screws " on the back " and make the balloon turn, they will also be at solar midday all at the same time, thing they will of course check.

Furthermore, after having seen a globe or sketches seen in a book, some will ask themselves what could happen with a " leaning Earth " : they won't easily admit that the shadows at solar midday could point the poles in the same way they do with the balloon " straight " on its base. But how can they see it ? The simplest -and funniest- way to do it is to hold the balloon between their fingers placed on the " poles ", tip it slightly and make it turn with the thumbs : the children will see that, whatever the inclination -even when the balloon is " horizontal "-, the shadows in the solar midday are still lined up on the meridian !

Fig. 8

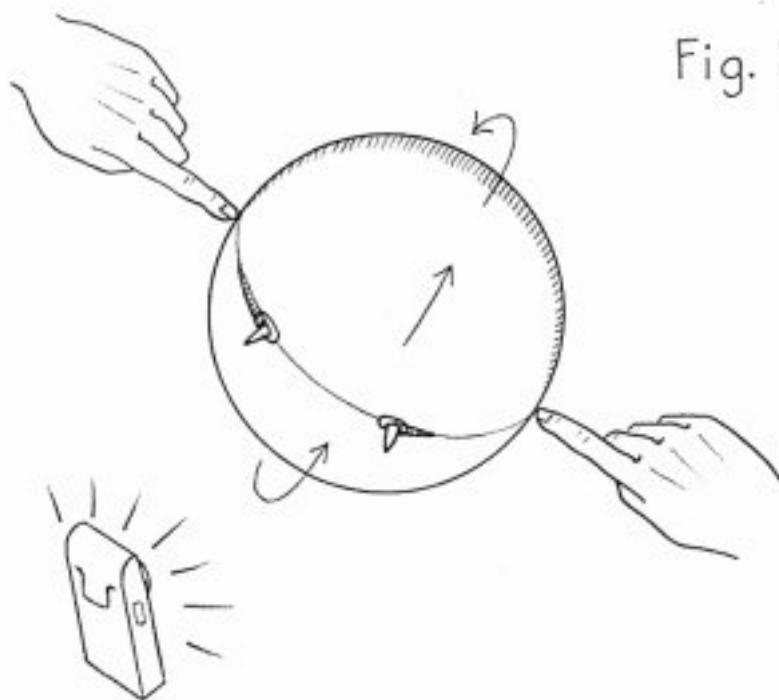

Second session

a) Reproduce solar midday in Alexandria and Syrene.

Because the two cities are not on the same meridian (about $3^{\circ},5$ separate them in longitude, like Le Havre and Auxerre in France), the pupils will have other problems to solve.... Give the retailed mini-map of Egypt to each group (see Equipment) and challenge them for the third time : " Place the map on the balloon so as to reproduce Eratosthene's observations : solar midday in Alexandria and Syrene ".

When the two screws will be put upon the mini-map, the pupils will place it vertically upon the balloon, facing the light, and make it slide until the shadow in Syrene is reduced to the minimum, then they fix it. Bu the problem is that the shadow in Alexandria " is not exactly straight ", and is not pointing the north pole. (This should be easily seen, even if the objects are small, because of the difference between the width of the paper and the curve of the balloon).

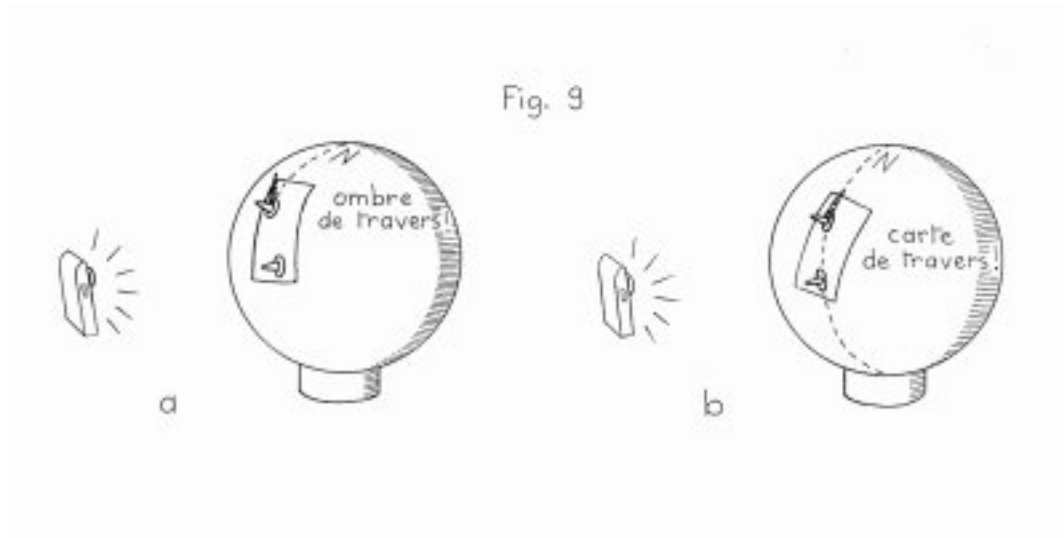

To compensate, the children will slightly turn the balloon, and the shadow will straighten -and shorten, also-, but the problem is that a small shadow appeared in Syrene !

Remembering the previous simulation, some will want to put the two cities on the meridian drawn upon the balloon. They will make the shadow in Alexandria point the north pole, and the one in Syrene disappears. But the map is now bent ! Suggest then to " righten " the map and carefully survey the movement of the two shadows from " sunrise " to " midday "...

The children will discover that in Syrene " solar midday comes slightly before Alexandria " and again, there is a problem with the text saying that Eratosthene's observations were made at the same time... But which time were they talking about ? Not watch-time -no watch existed at that time-, but the time given by the Sun, so different from one place to the other around the Earth, exactly the same as with the balloon ! They also understand that the two cities are on different meridians, and that it could be possible to draw an infinite number of meridians on a sphere. We will get back to that point.

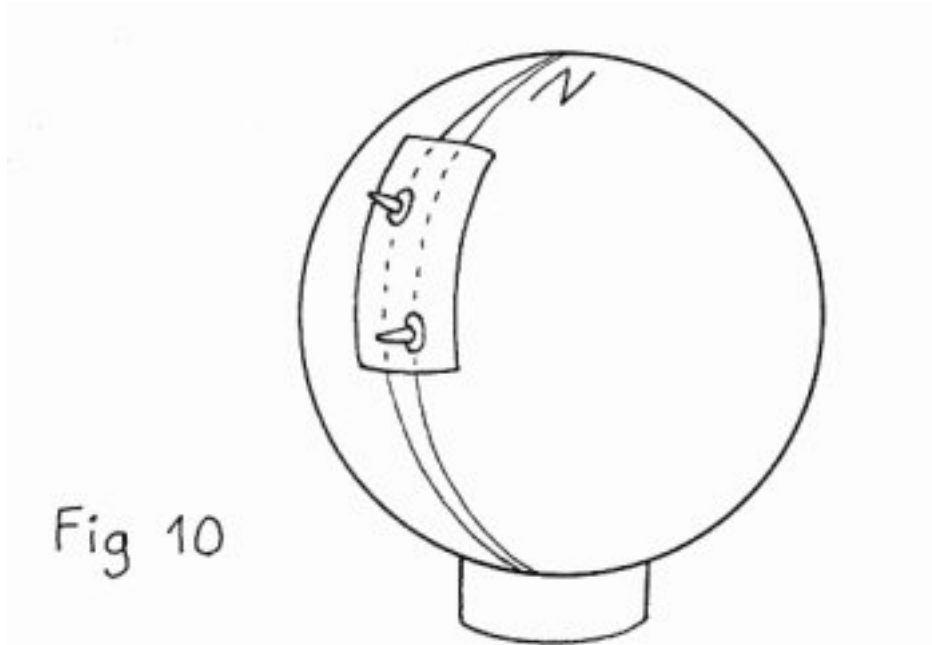

Fig 10

Note : Specify if necessary (or have your pupils calculate it later) that there is nearly half an hour of difference between solar midday in Syrene and in Alexandria, but this slight difference did not hamper Eratosthene when he computed the meridian...

After that, the pupils will understand that in our modern world, one cannot live anymore at Sun-time : a state must have the same hour on its whole territory, and all the countries in the world must agree upon a common " legal " clock system (we'll see that later).

From another part, the use of a balloon lit by a torchlight can also simulate in an entertaining way the evolution of the shadow of a mini-gnomon with the seasons (see file about the seasonal changes of a gnomon's shadow)

b) How to know the time of solar midday anywhere all along the year.

How can anyone know in an easy manner, for the rest of the project, the exact local time of solar midday, in order to make only one shadow survey ? Several solutions can be used :

1. Use a compass to determine north, knowing that the direction is slightly different from geographical north, therefore making a slight error. Then, the pupils will only have to watch the shadow, to see when it crosses the north line.
2. Draw upon the base of the gnomon (carefully placed on the ground) what is called a meridian : a fragment of the actual meridian, in order to get the geographical north. This is a very interesting thing to do, once and for all, optionally (see the file : " draw the meridian ")
3. Connect you to [the site of the B.D.L.](#) (Bureau des Longitudes) who, according to the place you are and the date chosen, will give you the time of solar midday, but in Universal Time. In France, you'll have to add 1h if you are in winter time, and 2h in summer time.

(Note that when you have made the first drawing at the time given by the B.D.L, you will be able to draw the meridian of the place, since it will be the same as the shadow drawing)

Finally, you can also continue this session with [the games devised by J. Carole in 2001](#) : she shows how to materialize Sun's path on a transparent half-sphere (an upturned salad-bowl or a very fine colander).

This can be made any time in the year, provided the sky is clear !

In the following session, the pupils will tackle with the question of the angle of sunbeams : how to draw, measure and interpret them.

Optional file (Sequence 3)

A " Sun calendar" with a sample of shadow drawings

How can shadow be used as a " calendar " .

At least ten days (even more) after the great moment of the last shadow survey, the pupils put the gnomons back under the Sun with the sheet of paper of their previous drawings, to see if the shadow will get back to the place it were on the right time. In fact, no ! From the first observation in the morning there is a clear difference, as if the shadow was " late " (if after the 21st of December, or " soon " if it's before). So, the pupils can put another sheet of tracing paper upon the first, and, when they draw this shadow, they can see that it has shifted, and that it also is shorter (or longer). The gnomon cannot be responsible for that, and the pupils can deduce that " The Sun is not exactly at the same place as the other day ! ". The observations during the other hours of the day will confirm the phenomenon, except one moment : solar midday. This shadow has not shifted, it is only slightly shorter (or longer).

However, an exact reading at solar midday can show a slight shift regarding watch-time, which may mean that solar midday is not exactly as the same time as ten days before. Other readings will show that this shift changes all around the year, changing the time of solar midday compared to " official " time. This is because " official " time doesn't count some changes in the course of Earth, caused by the fact that the axis of the poles is not perpendicular to the plane of the course of our planet around the Sun, and that this course is not exactly circular, but slightly elliptic.

Note : It is also possible to observe these changes with a calendar showing sunrise and sunset, and study with a graph the changes of the time of midday (sunrise time minus sunset time divided by 2) during the year.

The pupils will see then that the changes in the new drawings show a symmetry regarding the spot of solar midday, their " fan " having slightly " opened " or " closed " .

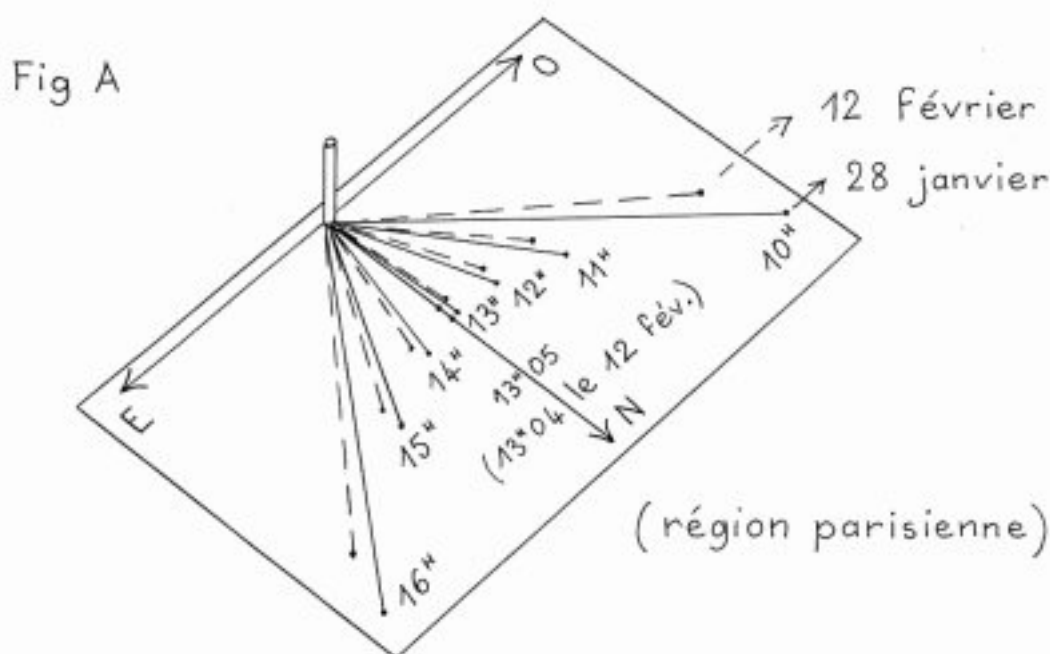

If they know how to explain why the length of their drawings have changed, they will have problems to

explain why they " opened " or " closed ". This is in fact a question of space geometry (field of cones) : the tip of the shadow draws during the day a curve called hyperbola, evolving and reversing from one solstice to the other, becoming a simple line at the time of the middle phase of the two equinox. Reason of the interest of making other drawings several times in the year to follow the changes.

Useful notes about Sun " calendars " .

The figure below shows, in a theoretical way, the " fans " of shadow drawings of the same gnomon (under our latitudes) during the solstices and equinox. We can see that the symmetry is set by the shadow at the time of solar midday, simplified as midday hour. So, the two symmetrical drawings of each pair are of the same length. But there is generally a difference of length between the two, giving a general dissymetry to the fan, more or less important. Why ? It is because the surveys have been made each hour on the dot, and that the real time of solar midday, as we have seen, is not exactly at 1 PM (or 2 PM) in a given place : these readings cannot give the real axis. A second problem arises : the angles in the drawings of the same fan are not equal in fact, at a minimum in the early morning and late afternoon, and at a maximum around solar midday, for a question of space geometry the pupils would have problems to understand (but this won't affect the project itself).

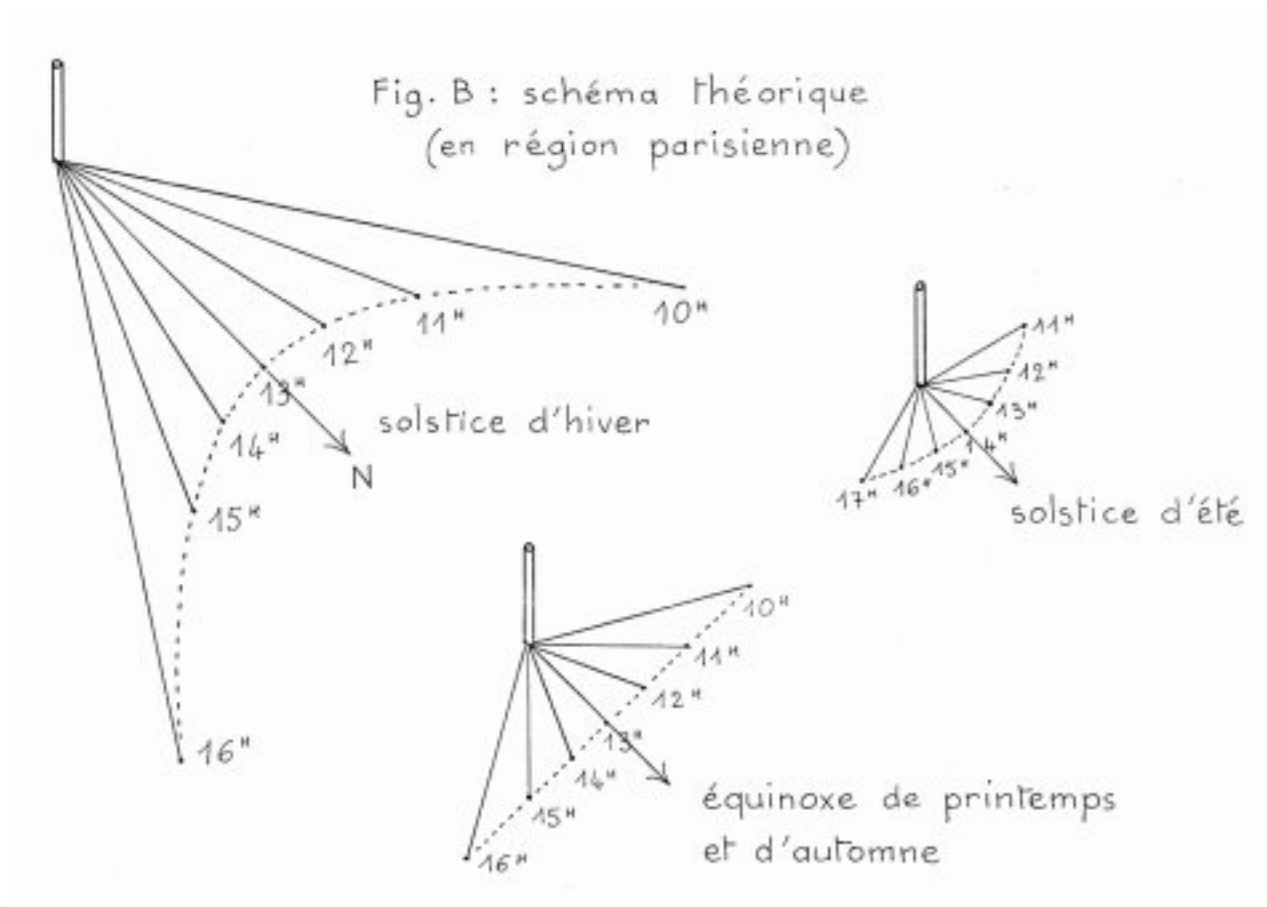

Optional file (Sequence 3)

Simulate the seasonal changes of a gnomon's shadow

The simulations given here are about the evolution of the line made by the tip of a gnomon's shadow during the day, from season to season. There should be, prior to these, several sessions of surveys throughout the year (2 every 3 months at least).

Simulation during spring (or autumn) equinox

After the surveys made in autumn or winter and the following simulations, your pupils will possibly think that the shape of the curve described by the tip of the shadow is the reversed reflection of that of the Sun (or their lamp). This new simulation will prove them against it. It would be best to make before a new survey very close equinox, after another made two weeks before, in order for your pupils to see that the curve slowly becomes a right line ! (prepare sheets with a simple right line, long enough, ahead of the gnomon's base). Using their lamp as before, the children will understand that is " has to " describe a curve ! (And they will understand that the rules of geometry implied in that are not so simple as it seems...).

If a new session comes shortly after the equinox, the pupils will see the new tendency of the line linking the ends of the drawings : tell them to anticipate what it will become, write down what they think, and check it on the field on the next session. It is probable that, towards the end of the project, some pupils will be able to predict effectively what the curve is going to look like during summer, and then autumn : but they will be able to check it only with a gnomon made at home. (the figure below is to be compared to figure B in the optional file " Sun calendar with a sample of shadow drawings ".)

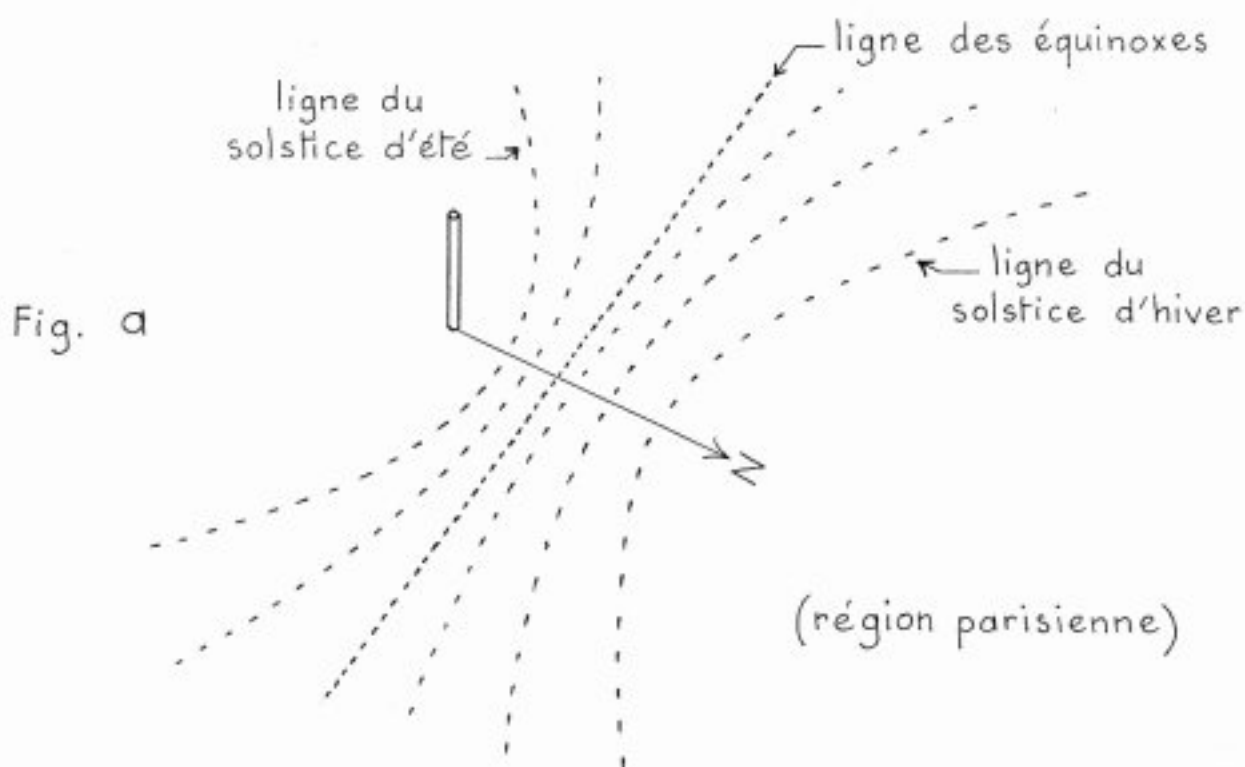

The two equinox have their interest also, relatively to the angles of sunbeams at solar midday, as well as... latitude. If your pupils already know these two notions and began a few measures of the angle, they will see that on any equinox day, the value of this angle is equal to the latitude of their school !

This day, Sun illuminates Earth in a very particular way. Our planet being lit by half, the circular limit of its " day " half goes exactly through the two poles : a gnomon -on the " real " Earth- placed on these two points would have an infinitely long shadow since the Sun strikes horizontally, and the angle goes up to 90° (effective latitude of the two poles).

Inversely, at the equator, the Sun striking the gnomon vertically (there would be no shadow), the angle would be null (latitude 0° for the equator). In the same way, all other places on the Earth get, this day, the precise value of their latitude for their angle at solar midday.

Simulation of the seasonal changes with a balloon

(See before part 4 of session 3)

A tiny gnomon of modeling clay is fixed upon a balloon lit by a lamp. The pupils try to draw the moves of the shadow's tip as the balloon is slowly rotating with its moving base. They compare the line obtained (1) with the ones they already got on their tracing paper (outside) and they devise a way to reproduce one of these lines...

They are instructed to keep the lamp from moving and not to move the gnomon. They will finally understand that, on solar midday, they will have to slightly tip their balloon facing the lamp. Either to the fore for a " summer line " (2) or to the back for a " winter line " (3). On the following figure, the line of the equator shows how to do it :

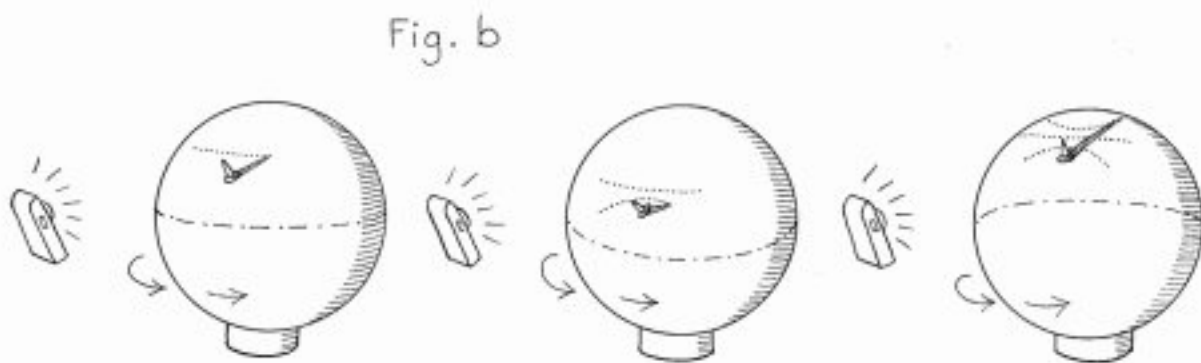

But... Does Earth really tip in space during the year ?

This is a very interesting question the pupils will be able to solve, using this time a globe turning around a circle of lamps representing the Sun : they will see, for example in France, that to get the same effect during the course of the globe, its axis will have to be parallel to itself at every point : when the axis seems to tip towards the " Sun ", it will be summer in France, and when on the other side it seems to tip backwards, it will be winter. The pupils will deduce the position of the globe in spring and autumn.

Sequence 4

Measure the angle between the solar rays and the vertical

Introduction

During this sequence, the children will have the occasion to get more familiar with the notion of angles. They will build a gnomon, emblem of the project, and will carry out their first measurement of angles between the solar rays and the vertical, like our scientist Eratosthenes. We advise you to read very carefully the technical assistance n°4 in order to evaluate the precision of your readings and to improve it as you go along.

During this sequence, you are going to make your first measures with the gnomon Eratosthenes. We advise you to read carefully [the technical assistance N° 4](#) in order to assess and improve its accuracy.

Notions

Notion of angle, of equality of angles. Schematization of the angle of the solar rays compared to the vertical. Approach of the notion of proportion. Using a protractor. Use of a chart of measurements. Comparison and interpretation of these measurements. Evolution of the angle of the solar rays during the year.

Preliminary : Eratosthenes 's measurements

After having discovered with Eratosthenes the moment of the solar midday, the children will dive into the first specific measurements to the project itself... Suggest to read them the short text following that will invite them to discover the notion of angles :

" Eratosthenes having chosen to observe the shadow of an obelisk located near to the entrance of his library wanted to know more. He decided to measure precisely the angle between the solar rays and the obelisk of which he knew the height : around 8 meters. He waited for the sun to be at its highest in the sky, and measured its shadow and found exactly 1 meter. He concluded that the sun rays at that precise hour made an angle of 7.2 degrees with the obelisk, it was june 21... "

Now get to your notebooks : will you be able to discover how Eratosthenes found the value of the angle and measure it yourselves ?

Summary of the sequence :

This sequence is composed of four parts, each one of one or two sessions, or a simple punctual activity at lunchtime (or else at the beginning of the afternoon since we just changed to summer time!).

1) Works of approach on angular measurements

2) Find Eratosthenes's angle measurement

3) Building the solar stick "Ératos"

4) Angular measurements specific to the project with the solar stick "Eratos" .

1) Works of approach on angular measurements

Duration : 1 hour, entire class.

Location : classroom



Equipment :

For each group of 3/5 pupils :

set squares,
rulers,
protractors,
tracing paper,
white paper and graph paper,
color bristol boards and scissors

Remark on the difficulties related to the concept of angle and activities to help it out by Valérie Munier, laboratory of didactics of science at Paris VII.

During this sequence, the pupils will have to use the concept of angles. They often tend to define an angle from the data of two segments of the same length and origin. Therefore, two figures whose only difference is the length of the sides will appear to be representing two different angles. It will therefore be interesting to insist on the fact that the angle is defined rather by the measurement of the spread between two directions materialized by straight lines or segments of whatever length. They will then be able to represent the direction of the solar rays and of the vertical (the obelisk) with segments of variable lengths and check that the angle they measure with a protractor is the same in any case.

If you wish to make them materialize their angles, you can use bristol board and make angular sectors drawing a section of a circle to note the angle considered. That way they can have fun comparing an angle with others by sliding a board on top of the other, superposing the summits of the angles to be compared. They can also look around them for a place in the class where they can find natural angles with furniture, walls and slide their board into any corner. They will notice that way that some angles are more or less pointy, more or less open, and therefore more or less big.

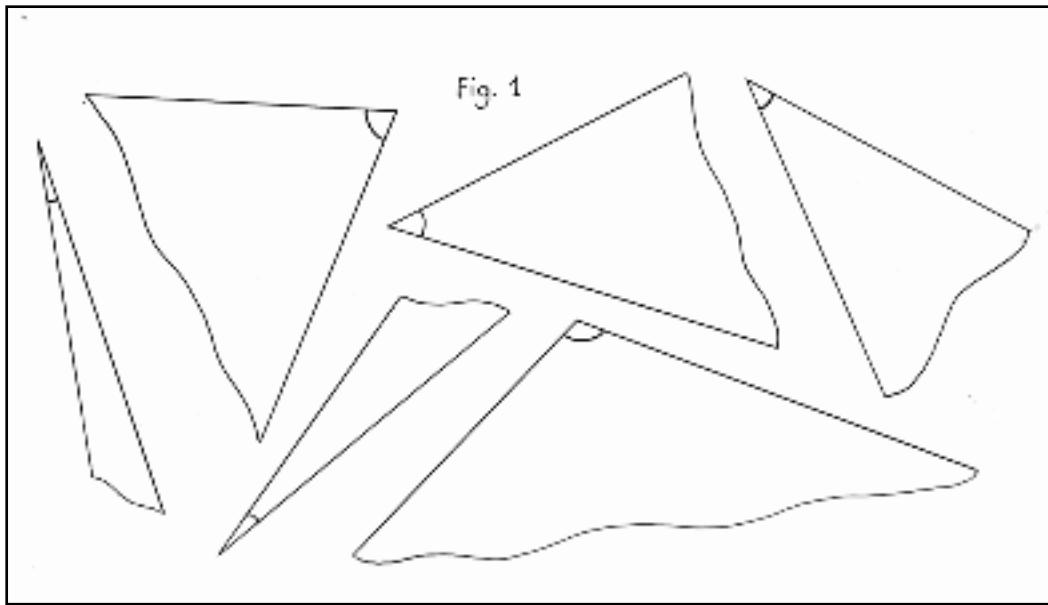

They can also look around them, in the classroom, for several angles : but they will see that books, notebooks, furniture, walls, windows... all have equal angles, since they are straight angles, and that therefore it has nothing to do with the length of the sides.

Drawing the angles of the solar rays - approach of proportionality

The children wonder about the challenge given at the end of the text, and you suggest them to make a drawing representing the obelisk and its shadow, reaching with them an agreement on the scale and using the graph paper or the squared paper. However, there could be a question in the class : how are we sure that the inclination of the rays will be the same as on the drawing? To put it differently, is the angle between the solar rays and the obelisk the same when you change the scale or is it also divided by the scale factor? The children debate about this tricky question and have their own hypotheses, which they write down on their science notebook before trying to check them by making an experiment themselves by making different drawings.

You can ask the following question : " Will the shadow of a gnomon that is twice longer be twice longer at the same hour of the day? Will the angle be doubled? " The answer is of course yes to the first question and no to the second one. The research of the answers will make it easy to tackle with the notion of proportion.

To the first question, the children will probably answer " yes, the shadow will probably be double " and they will check on a simple drawing on paper : here, simple sheets of 5 x 5 mm will do it perfectly. You can also carry out experiments with the sun to convince them better.

They start by drawing a little gnomon (8 cm) and choose the slope of the solar ray by counting the squares down and right to join two points of the ray. They chose the inclination of the rays on the sheet and can then easily reproduce a ray that is parallel to that one by counting the squares, a little farther. Drawing the first gnomon, they draw and measure the shadow on the ground being careful about drawing the ground with the ruler, perpendicular to the gnomon. They therefore get a first rectangle triangle (a triangle that has one angle of 90 degrees).

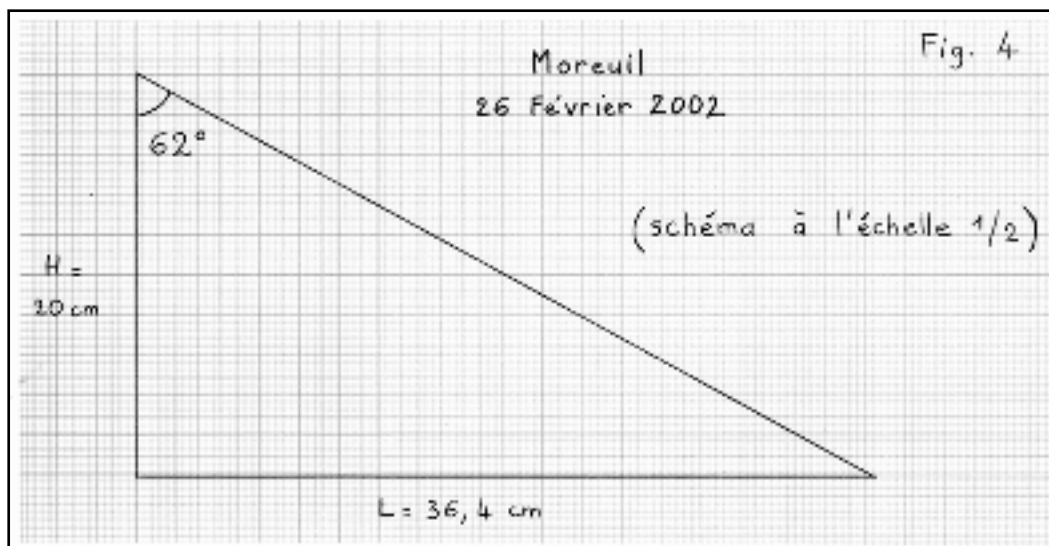

Then they draw a gnomon next to it that is twice smaller and draw a solar ray parallel to the first one and that touches the tip of the gnomon, they draw it to the ground represented by a horizontal line and measure the shadow they obtain as well as the angle of the gnomon with the ray (they can use one of the Bristol cards or a protractor. If it proves to be difficult, *they can make a mini-gnomon with Bristol or a mini-obelisk cutting a rectangle of 1 square of width and the desired number of squares for the length, and they will cut the tip sharp, making sure the length of the gnomon is 4 cm, half of the other one.* They can do the same with a bigger rectangle twice smaller, 4cm.

With the same solar ray or a parallel one, they look for the correct position of the gnomons for the foot to touch the ground and the tip to touch the solar ray. Then they draw the shadows and their measurements. They can also write down the value of the angle and notice that the angle hasn't changed whatever scale you choose. However, the shadows are in the same ratio : a gnomon that is twice as high gives a shadow that is twice as long and a gnomon that is twice smaller gives a shadow that is twice smaller too!

What would happen if the gnomon were 3 or 5 times bigger (or smaller) ? The shadows would be 3 or 5 times bigger (or smaller). What would happen if we used a solar ray that would be more inclined and if we carried out the experiment again? *It would change nothing to the conclusions, it is independent from the inclination of the rays provided that the inclination does not change between the gnomons you compare (that was checked because the sun rays that reach us are parallel, cf Seq. 1)*

Conclusion : you can choose the scale you prefer to draw the gnomons and their shadows, it is only a matter of convention and it does not bother for the measurement of angles which is identical whatever scale you choose. You can now decide with them which scale to use to represent Eratosthenes's scale and try to find his angle. You will complete these activities initiating them to the reading of a protractor, they will then be able to measure any angle around them in the classroom.

2) Find Eratosthenes's angle measurement

Duration : 15 to 20 minutes for the sketch and the measurement of the angle ; 45 mn to 1h to use the chart of measurements.

Location : classroom



Equipment:

sheets of millimetered or squared paper,
tracing paper,
enlarged photocopies of a protractor,
sharpened pencils,
rulers,
cisors,
protractors.

Then, photocopies of the chart of
measurements (See farther).

Find Eratosthenes's measurement

Distribute your pupils in groups of two. Deal out to each group a pair of cisors, color bristol boards, a piece of tracing paper, a protractor, a big sheet of squared or graph paper. On the latter, they must draw the obelisk, the ground and the shadow of June 21st . To respect the scale, you will agree to represent one meter in the reality with one or two centimeters on the drawings. Then, they draw the ray joining the summit of the obelisk to the tip of the shadow, making an angle appear between the obelisk and the ray. Then they trace the angle on the color bristol board that they will cut and measure with the protractor. They must find an angle close to the value measured in Alexandria, around 7 degrees. They will notice that it is impossible to read an angle of 7.2 degrees with their protractor, that they can only go by 0.5 at the reading.

If the gap is important, they will have to ask themselves why their measurement is bad and look for the causes of the possible mistakes on the drawing : is the obelisk perpendicular to the ground (check with the set square), is the solar ray straight, is the angle section well cut?...

Last, going back to their drawings of the shadow at the real midday, ask them to determine the angles they measured that week. Then they will be able to compare to the value of Alexandria the closest to this date. They will note the difference (by a direct measurement, a substractio or superposing to angular sections that have a different color) and they will try to explain it. Remind them of their experiment about the "earth-balloon" (previous session). They will probably remember that the shadows of the gnomons grew bigger as long as you went away from Syena North or South. In the first case, they would point North and in the second case South. They will check with a new balloon and fake gnomons that taking Alexandria as a reference, and they will locate their town in comparison with Alexandria where the shadow of the gnomon will be chosen arbitrarily (use an Atlas). According to the location of your country, the conclusion of this modelisation is variable, the children observe in different cases a bigger shadow (North of the Tropic of Cancer, in Europe and North America, and South of the Tropic of Capricorn) or shorter if you are in between.

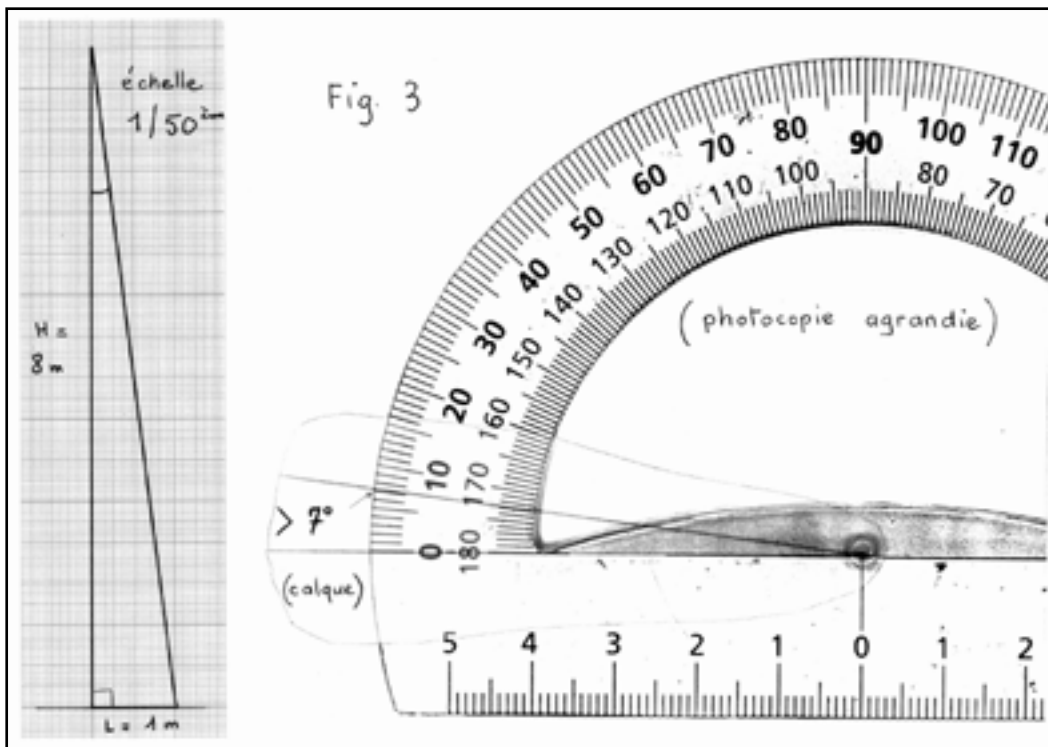

Option : A little practice!

In the following chart, erase a few values of angles or shadows and deal out photocopies to the pupils with the following sentence.

" We found the measurements that our great scientist could do during the year in Alexandria, they are given in the chart below, but some of them are missing... can you find them?"

Month	21 january	21 february	21 march	21 april	21 may	21 june	21 july	21 august	21 september	21 october	21 november	21 december
Length of the shadow of the obelisk in meters	9.9	7.2	4.8	2.8	1.6	1	1.5	2.8	4.7	7.2	9.9	11.3
Angle of the rays with the obelisk in degrees	51.1	41.8	31	19.3	11.1	7.2	10.8	19.2	30.6	42.0	51.2	54.7

They will have the opportunity to manipulate the protractor in order to fill in the empty boxes. It is a good practice before measuring their own angles. Then suggest them to try themselves to measure the angle between the solar rays and their gnomons at midday measuring the length of the shadow with great precision (they can start with the readings they already carried out if they were carefully). You can then compare your results with those of Eratosthenes and, like him, establish a list of regular measures

throughout the year.

As a conclusion, the children will notice in the chart of measures that the length of the shadow at midday - and therefore the inclination of the solar rays - varies during the year in a given place. They will probably already have noticed the evolution during the experiments from the beginning of the project. If it is not the case, the discovery will doubtlessly intrigue them and they will want to know more about it. Suggest them to visit themselves if it is also the case in their town. For that purpose, they will have to measure precisely in the weeks and months to come the length of the shadow of their gnomon and deduce the angle that the solar rays make with this "gnomon-obelisk".

The next session will be dedicated to the making of a gnomon for the class.

3) Building the solar stick " Eratos "

Duration : several sessions to discuss, build, adjust, and test the solar stick

Location : classroom and sunny place afterwards.



Matériel :

For the whole class :

Chosen materials,
tools,
" double square ",
water level,
compass.

Action in concert

A " full session " will take place to establish the specifications of the building of the solar stick " Eratos ". While taking into account the material constraints, notably the one on the dimensions of the support which should not exceed one meter, each child will argue and give his/her opinion.

Taking into account the fact that the shadows are going to lengthen until December the 22nd (date when, in France, the shadows at noon solar local time are almost three times as high as the objects), and that the blur of the shadow increases when moving away from its base, some children will decide to build a solar stick rather small, 15 cm seeming reasonable to them. Others will want a bigger tool for the simple pleasure to decorate it as a little totem: they will not hesitate to propose a 30 cm height.

Hence a consensus will be established for a solar stick being 10 to 20 cm high, having a cylindrical section but with a small diameter, with a flat end, and being attached to a rectangular support of about

100 cm x 80 cm. Beware with metal stick that heat under the sun and might dilate if exposed for too long a time.

Building of the solar stick.

The pupils being widely trained to this type of activity and teeming with ideas always more and more surprising (which ones will be rigorously examined before any action!) we will not be long on this subject. However moderation will be required for the support: no treatment that could warp its surface nor decorations that could interfere with the readings of shadow! ***Always be careful with solar radiance that could dilate and even buckle the materials you use if the temperature at the time of the measurements reaches 30 degrees. The board must not undergo the risk to warp, it must remain flat and plane.***

Orientation and adjustment.

On the side of marking the orientation of the support, and then the adjustment of the perpendicularity of the stick and the horizontality of the support (see the part " Adjustment of the solar sticks " at the very end of the sequence 2), it is obvious that the biggest care will be taken to this triple operation, which one will have to be verified and repeated if need be, before each reading.

Testimony from the school in Rocquigny (08), Mr. Pouyet, about the building of the solar stick :

"Here is how we have built our solar sticks:

First the children have built an individual solar stick:

-a thick cardboard plate on which a stick (rod, long toothpick) is fixed and with which they have performed the first readings ... barely reliable. Very quickly, one has had to take into account various parameters (horizontality and verticality) and finally our solar stick is made of:

-a plywood plate (2 cm thick) of 50 cm x 30 cm with a hole on one of its sides,

-a 15 cm screwed rod perpendicularly attached to the plate with nut and lock nut.

Then we have chosen a place in the schoolyard which is sunny around noon local solar time. We have checked its horizontality with the level and the measurements are all carried out at this place.

Hence we mark the length of the shadow of the solar stick on the plate and back in the classroom we reproduce at the scale $\frac{1}{2}$ on millimetered paper the triangle formed by the solar rays, the shadow of the solar stick and the solar stick itself. We measure the angle obtained.

All this does not take more than 10 minutes."

4) Angular measurements specific to the project with the solar stick "Eratos"

Duration : during several weeks, according to the weather, 15 min daily to read the shadow at noon local solar time, followed by a short session to determine the angle of the rays.

Location : sunny place, classroom.



Matériel :

For the whole class :

Angular measurements from the shadow:
the solar stick " Eratos ",
a roller meter,
several millimetered paper sheets,
yarn,
a protractor .

Preliminary: Tracing of the meridian line of your place. *You can refer to the corresponding optional slip. This plot is useful to precisely know the time corresponding to noon at solar local time every day, by observing the shadow of your solar stick passing over this imaginary line which joins the two poles of our planet passing by your school. If you are short in time to completely realize these activities simply trace this meridian by writting down once the precise time of noon at local solar time (information given by the ephemerides of your place or on the website of the Bureau Des Longitudes : <http://www.bdl.fr/...>) and by extending on both sides the shadow of the solar stick at this given time. On the ground, you will put two reference marks on each side of the support so as to quickly orientate your instrument before each measurement.*

At last, here is the actual beginning of the operation Eratosthenes!

Experiment:

Every day, when the Sun shines at mid-day and when the shadow of the solar stick " Eratos " can be observed while meeting the meridian, one pupil comes and puts a very precise reference mark with a pencil at the end of the shadow. Then he/she carefully measures the length of the shadow.

Schema:

With a pencil having a very fine point, the child copies on a millimetered paper sheet the height of the solar stick and the length of the shadow. Then he/she traces the solar ray by a continuous line joining both ends. If the height of the solar stick leads to a very long shadow (in winter time), the children are going to overcome the difficulty: they will remember that the angle is going to be the same after reproducing the schema at the $\frac{1}{2}$ scale for instance.

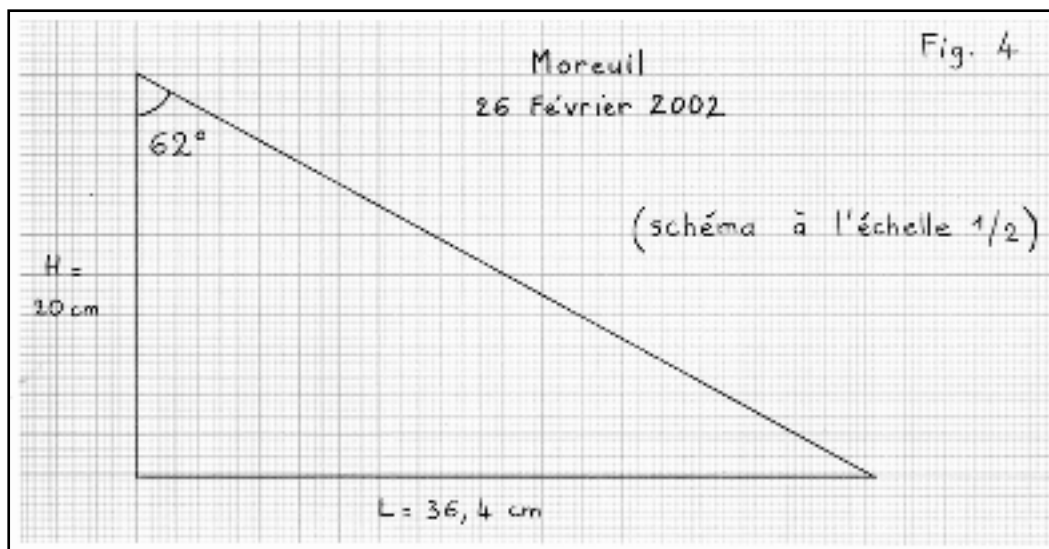

Measurement of the angle

One will only have to measure the angle with the help of a protractor and all the accuracy possible, that is to say at least within half a degree!

It will be helpful to ask that three pupils carry out the measurement in parallel, from the same initial reference mark of course (This is why this reference mark is so important): if two or three of the results agree in a very "short" way, you will be allowed to consider that this result is valid. Otherwise one will have to re-do the schemas.

Some pupils will want to try to measure the angle "on the field", that is to say by stretching a (very fine) thread from the end of the solar stick until the shadow's end and by using a protractor: they will see that the experiment is very ticklish especially when considering how to maintain the thread and how to adjust the protractor with respect to the rod of the solar stick! Nevertheless they will be able to compare their results with those obtained thanks to the schemas and to draw some conclusions.

Remarks:

- Long term observations: the children will notice that the marks on the meridian slowly move from one week to another, first moving away slowly towards the North until Christmas holidays, then starting to move back in January. They will deduce that the trajectory of the Sun, after reaching its lowest level in the sky in December, starts its slow climb. Then think of referring to the measurements in the Table of the shadows' readings in Alexandria and analyze with the children the similarities in the variations of shadow all through the year.

- If one day the shadow of the solar stick reaches the same length as the solar stick itself (this depends on your geographical position and more precisely on your latitude), the children will see that the angle is half the right angle, as when one double folds the corner of a sheet. Under the latitude of Bordeaux, that is to say 45° , this will happen on March the 21st, the equinox day, and obviously on September the 21st. About equinox, let us mention that schools of different latitudes will see on that day the angle of their own latitude! But we go too fast ...).

Schema: *With a pencil having a very fine point, the child copies on a millimetered paper sheet the height of the solar stick and the length of the shadow (measured to within a millimeter, it is very important). Then he/she traces the solar ray by a continuous line joining both ends. If the height of the solar stick leads to a very long shadow (summertime in the southern hemisphere), the children are going to overcome the difficulty after reproducing the schema at the $\frac{1}{2}$ scale for instance (they will remember that the angle is going to be the same whichever scale you choose, if they paid attention to the activities of approach about proportionality).*

Communications and exchanges

The values found for the angle will be carefully written down next to the corresponding date with the accurate time (civilian time - one can get this time from a watch adjusted on the speaking clock) and the place, in order to proceed to communications through Internet with all the schools involved in the project, and more particularly to exchange with correspondents when the groups will be defined. Don't forget to publish your measurements quite often and observe carefully the results of the other schools : the comparison between the measurements of the classes will lead to the next sequence and it will allow you to introduce the notion of geographical coordinates.

<http://www.mapmonde.org/eratos/measures.php?lang=en>

Sequence 4

Technical assistance for sequence 4: improve and evaluate the precision of your measurements

In order to ease out the exchanges between the schools, all the participants in the operation have been parted into 8 groups more or less homogeneous (plus one group for the Egyptian schools). Considering the distribution in latitude of the schools in the French territory, we had to assure a minimum latitude gap in the schools in each group. That is to say whichever group you are in, we tried to associate you with a partner that has a latitude with at least 3 or 4 degrees of difference.

Why? Because a correspondent that is 4 degrees south of your town will measure an angle inferior by 4 degrees to yours on the same day. Unfortunately, your measurements being only an estimation of the real angle between the sun and the vertical. As you might know, an estimation is always imprecise. Sometimes you will measure an angle that is superior to reality, sometimes inferior. This spread, this mistake, depends both on the quality of your gnomon (length and perpendicularity of the stick), and of the quality of the setting up (horizontality of the board, drawing of the local meridian). You will have understood that your measurement should be as precise as possible.

If the mistake you are making on each measurement is around 3 to 4 degrees, it is obvious that your calculus of the perimeter of the earth will be very far from reality, since your mistake will be the distance with your partner. If your measurement is reliable by 2 degrees, it is better, but your partner having around the same precision, there is a big risk that the difference should be cancelled! As a conclusion, it is necessary for your gnomon to be sufficiently well set to allow you to carry out measurements with a precision of (at least) 1 degree.

This technical card should help you control and improve your measuring instrument in order to publish quickly measurements that are as precise as possible. Among the schools that already published measurements, some of them already meet this criterion, therefore you can all do it! We wanted to gather in this card a number of advice and ideas to help you out. Of course, these are only suggestions, and the list is not exhaustive... Don't hesitate to contact by e-mail the other schools of your group and to exchange your technical tips, that's what the discussion groups are for!

Repeated mistakes!

Every time you assemble two parts of your instrument, or that you set up your instrument before a measurement, you inexorably make little mistakes, that, put together, might well have your measurement fail. Sometimes luckily your mistakes compensate each other, and sometimes they add up and damage your results severely, it is therefore important to control every step meticulously.

Make a list with your pupils of the different stages that lead to each measurement, from the making of the gnomon: choice and measurement of the length of the stick, fixing the stick perpendicularly to the board that is also supposed to be perfectly flat, setting up the board and checking its horizontality, drawing the meridian, locating the passage of the shadow of the stick over the meridian line, measurement of the shadow, drawing the angular sector thanks to the lengths of the shadow and of the stick, and eventually measurement of the angle.

You now have to admit that on every step of the way, you made a slight mistake. You can understand that the final measurement and therefore the calculus of the diameter of the earth can be very far from the reality! Let's see now a number of tips and ideas to evaluate and minimize these mistakes.

Basic rules

How to reduce to maximum the error in the measurement of an angle? By increasing as much as possible the length of the sides that you draw to measure the angle (see figure 1). Indeed, you can never know exactly the length of something, but you can measure it with a certain precision (give a double decimeter to three pupils and ask them to measure one by one the size of your desk with a precision of half a millimeter : they will surely find three different measures!).

Suppose now that you wish to measure the angle alpha represented on the figure 1 below from the knowledge of the length of the segments A and B. Suppose that the length of A and B have been measured with a precision of 1 mm (reasonable). The figure shows you that the uncertainties on the measures of A and B lead to one on the knowledge of the angle alpha itself.

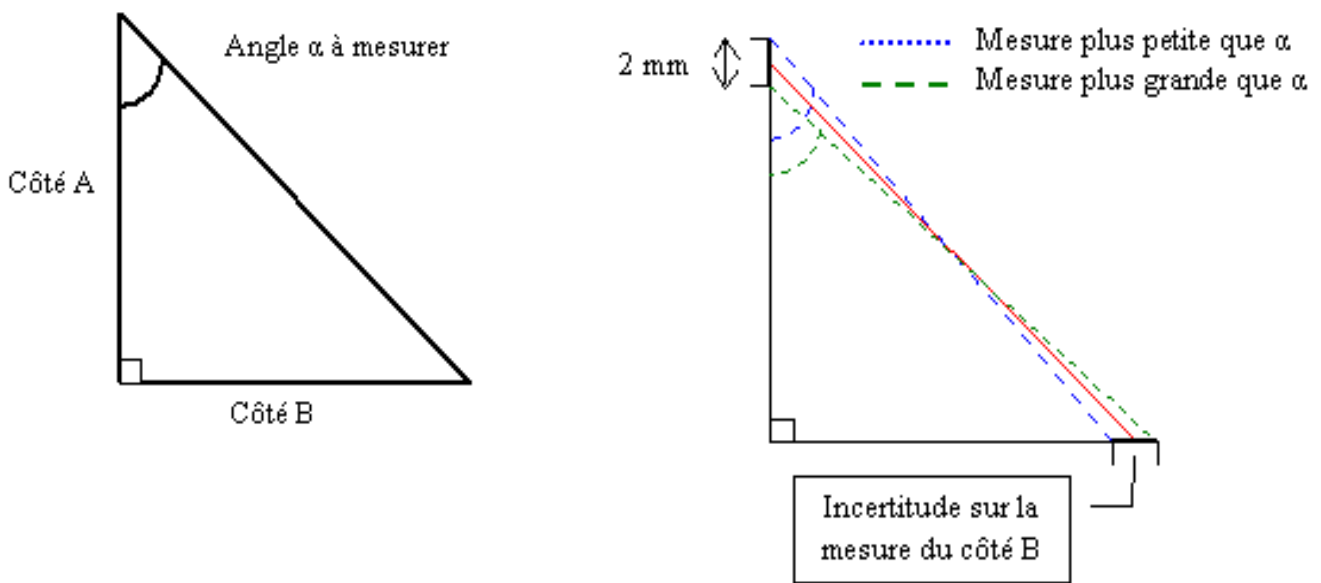

To reduce the uncertainty, now triple or quadruple the length of A and B. The uncertainty on the measurement is the same (it only depends on the way you measure : quality of the ruler and of the reading). However, the uncertainty on the angle decreases. You should be convinced by reading figure 2 : notice the extreme angles, as a consequence of the uncertainties, they show the limits that surround the angle alpha : here 45 degrees. This interval decreases indeed on the biggest figure (check with your protractor!). Therefore, it is your interest to use big length to measure angles.

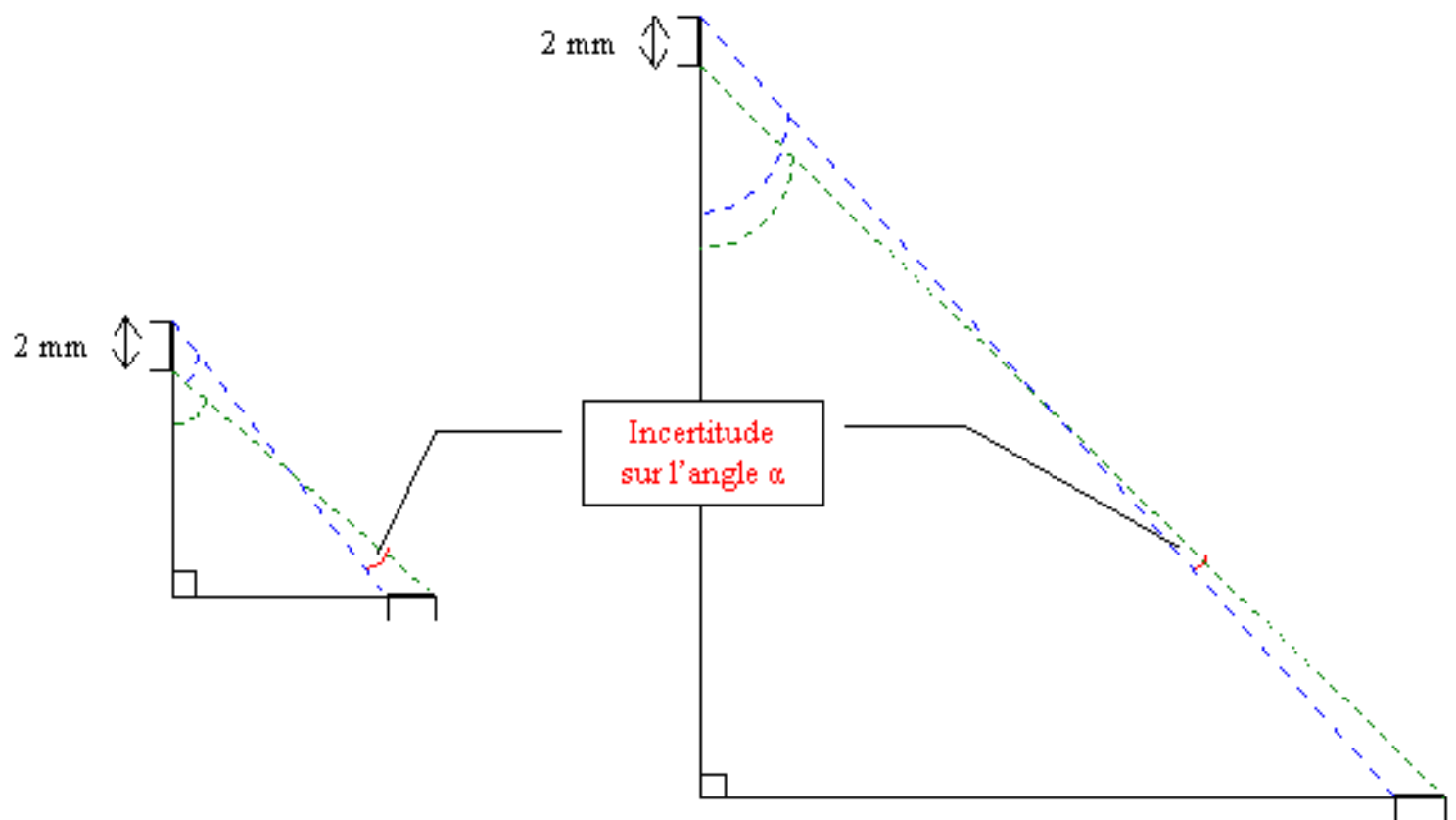

Applications

Use preferably big instruments : a square to check your gnomon is indeed perpendicular to the board.
Beware : you have to check in two perpendicular directions to each other, that is to say turn 90 degrees around the foot of the gnomon and check again in the new direction. Indeed, the gnomon can be inclined in any direction!

A longer gnomon will be easier to set up perpendicularly to the board, however, if longer than 20 cm, the shadow will soon become blurry, even at solar midday. Choose rather a 10 cm gnomon.

If you made a bubble leveller to control the horizontality of your board, it will be much more precise if the surface of the water is wider, according to what we explained previously.

Preferably use pencils with thin lead (like "criterium") to draw the measured lengths, that way you will reduce the mistakes in the reading of angles. As well, use big protractors to read the final angle, you will reach a higher precision in the reading.

Remark : according to the shape of your gnomon (pointy or flat at the top), you will have to measure the length of the shadow from different points of the foot, observe carefully the figure below because you would risk to make always the same mistake in your results.

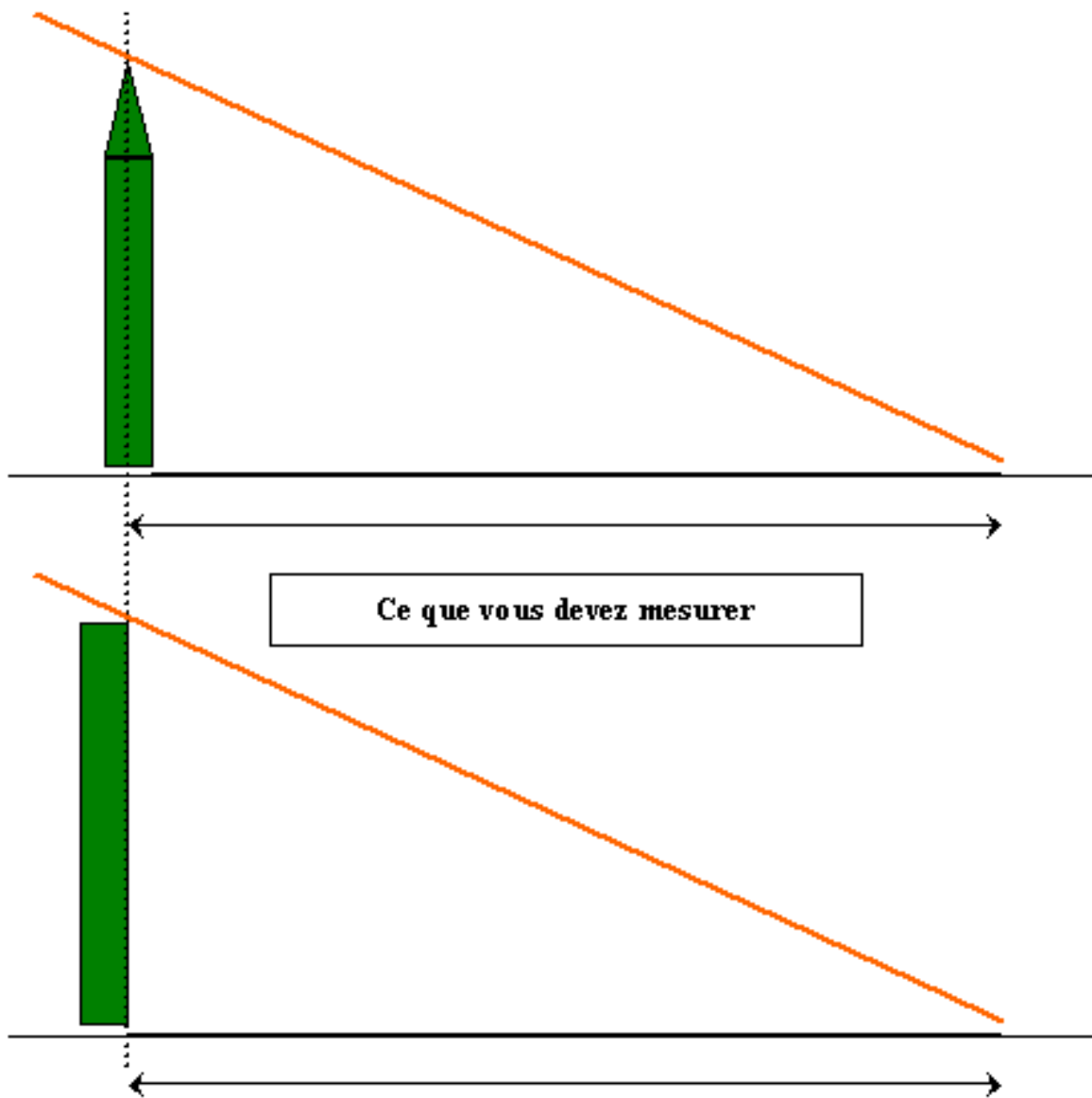

Evaluate your precision yourself

To get an idea of the precision of your measurements, it is very simple, you just have to do readings every day. From one day to the next, the value of the angle of the solar rays to the vertical varies very slightly (between 0.1 and 0.2 degrees in may). It is sufficiently low a variation for you to be unable to notice it in your measurements. Therefore, carrying out three measurements three days in a row, you will have an idea of the random mistakes you make while setting your measuring instrument. You should get three measurements that are as close to each other as possible. However, you will not be able to know your mistake in relation with the real angle you are measuring.

But, don't worry, we are checking your results very precisely and we will be telling you the real precision of your readings when we interpret your results. Good luck to you all, you are almost there!

Complement :

Here is the description of the gnomon made by Alain Rouquet and his class with their protocol. This gnomon, very simple in the making, gives very good results !

“For the realization of the gnomon, nothing very original : a melaminated fibreboard set on a table and on one of the sides a wooden stick of 10 cm, with a round section (8 mm), set tight (not too much for the children to

be able to readjust it at any time) with a clamping ring for copper tube (plumbing).

For each measurement, there is someone to check the horizontality of the board and of the verticality of the gnomon, a child draws on the board the extremity of the shadow and back in class, a team is in charge of tracing the triangle and of measuring the angle. A last team goes, very excited, to the computer to publish that day's angle on the website.

By aiming directly, it is quite disappointing, the measurements are hard to obtain with precision even if the children love to observe the sun with "eclipse" sunglasses.

A few illustrations of the [project are displayed on the class website.](#)

Sequence 5

To measure Earth's size

Introduction

At last! this final sequence will crown the efforts and perseverance that were yours all along this project. Congratulations. It is time to use the data you have carefully collected, either through your own survey, or through the other classrooms by Internet. We are now going to measure together the length of your meridian and finally find the size of our planet.

Note : This last step is the most tricky in the project, that's why we opted for a progressive action, in order to lead your pupils to the final calculation.

Link with the syllabus of the primary school (BO N° 1 of the 14/02/02) of cycle 3 :

- *Experimental and technological sciences :*
 - The subject : horizontal and vertical plane : interest for some technical devices.
 - The sky and the Earth :
 - light and shadows
 - the apparent movement of the Sun.
- *Mathematics :*
 - Space and geometry :
 - use of maps and plans.
 - use of tools (rule, set square, compasses) and techniques (foldings, tracing paper, cross-ruled paper).
 - geometric relations and properties : alignment, perpendicularity, parallelism.
 - Magnitude and measures :
 - keeping track of time and duration (year, month, week, day, hour, minute, second) and their relations.
 - angles : comparison, reproduction.
 - Exploitation of numerical data :
 - questions of ratio.
 - use of data in lists and tables.
 - View of the world : compare the global representations of the Earth (globes, planispheres) and the world (maps).

Link with data files :

Data file N° 17 : Light and shadows. 

Data file N° 19 : Apparent movement of the Sun. 

Excerpt from the text about the application of the new experimental and technological sciences programs :

Specific skills :

? To know that locations are relative : a place is east (or north) of another, but west (or south) of a third.

? To be able to imagine the apparent course of the Sun in the sky and its changes during the year. To know that it is at its shortest on the winter solstice (the Sun is then low on the horizon) and at its longest on the summer solstice (the Sun is then high in the sky)..

? To be able to use a calendar to determine the characteristics of each season and the dates that mark the beginning of each. (maths)? use a plane or a map to locate an object, anticipate or make a move, evaluate a distance

Comments :

The measures taken by groups of pupils will give an opportunity to compare the results and tackle with the question of accuracy of a measure. It is not necessary to introduce the idea of uncertainty and you should certainly not use the according formalism. We only need, in link with the mathematical field about decimals, to suggest a thought about the number of figures it should be reasonable to use to express an experimental result.

Summary of the sequence:

1- How did Eratosthenes measure the circumference of the Earth

a- The vertical at the scale of the Earth

b- To discover the secret of Eratosthenes

c- To measure the length of the meridian

2- To use the surveys of another school to measure one's own meridian

a- To choose your partner

b- To make your own Eratosthenes' figure

c- To measure the distance between two participating cities

d- To find the length of your meridian

e- To find the diameter of the Earth

f- To publish your measures in the results table

g- To send a postcard to all the members through our site

3- To try the historical experiment with an Egyptian school on the 21st of June

First : Eratosthenes' measure

Our Greek scientist was at the end of his considerations, and he tells us the results of his experiment. Give the following text to your pupils :

"Having measured the angle between the sunrays and the vertical -the obelisk in his city of Alexandria-, Eratosthenes drew on the ground a section of the Earth following a meridian. He put on it the cities of Syrene and Alexandria and drew the sunrays getting to these two cities. He compared the angles of these rays with the vertical in each of these towns and extended the sunray from Syrene to the centre of the Earth, and had the sudden idea to measure the circumference of our

planet.

Soon, he understood that something was necessary to complete his project : the distance between Alexandria and Syrene. He knew that caravans going through the desert were used to measure the distances between cities. Men who were called "bematists" walked beside the camels and counted their steps. Knowing the average length of a step, they deduced the distance they had walked by multiplying this length by the number of steps to make their trip! There was approximately one million steps between Alexandria and Syrene... That meant approximately 5000 Egyptian stadiums (a unit they used at that time).

Eratosthenes rapidly discovered after a few simple calculations that the circumference of the Earth was exactly 250 000 stadiums. He told that to his colleagues scientists and geographers and the news spread all around the Greek world that a scientist named Eratosthenes had for the first time measured the size of our planet."

Now, it's your turn ! Try to reproduce the figure taht made Eratosthenes famous in the whole world and discover how he could measure the circumference of the Earth. The, use your own measures and those of a partner school to find the size of our planet by yourself.

1- How did Eratosthenes measure the circumference of the Earth

a - The vertical at the scale of the Earth

The pupils, having read the text in the classroom, are going to ask various questions. The first thing to make them understand is the notion of vertical in the two cities of Syrene and Alexandria. If they have understood the activities about the notions of verticality and horizontality, they will certainly have a good idea of their local vertical. But what happens when it comes to the scale of our planet?

Ask them the following question :

"When the gnomons are adjusted (see the part about this activity if necessary and the notes they had taken in their notebooks at that time), how are they with regard to the horizontal support?" They will readily answer that they are vertical and as such perpendicular to the horizontal ground.

"What would happen then for gnomons all around the Earth?"

They will discuss about that and note in their books their hypothesis, to be checked by an experiment. For that, they can use a simple strip of stiff paper on which they will stick small shafts or pins, perpendicular to the sheet. The gnomons as they see them around them when they are adjusted. Since they are convinced that the Earth is not flat, they curve the strip and see that the gnomons are not parallel anymore, but that the directions to which they point are changing. If they close the strip upon itself, they will see the gnomons radiate from the surface of the Earth. They can draw on their notebook this strange figure of Earth covered with shafts just like a hedgehog.

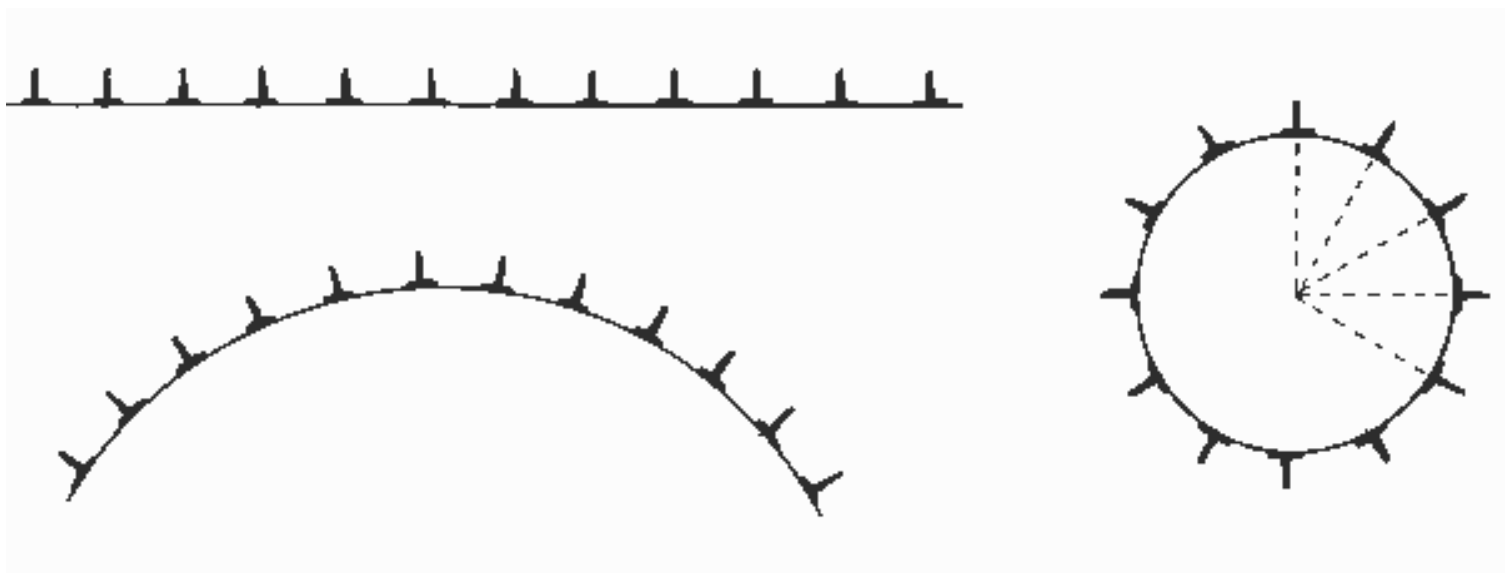

Figure 1

Seeing that all these gnomons are the vertical for each point of the Earth, ask them what happens when they extend by imagination all those shafts inside the Earth? They converge all to the centre of the Earth! It can be checked if you use the experiment, and replace the shafts by long needles or skewers.

They conclude that the vertical to each point of the Earth also points to the centre of our planet, and as such, the gnomons in two far away cities are not parallels but that their directions make an angle.

Then, draw on the blackboard a circle for the Earth and ask them how they could place on that figure the cities of Syrene and Alexandria, using what they know about Eratosthenes measures.

b - To discover Eratosthenes' secret

The question is difficult and you will help them find the answer that will lead them to the famous figure made by Eratosthenes!

The small historical texts told us that in Syrene, on the 21st of June at midday, the sunrays got down to the bottom of the wells and that vertical objects had absolutely no shadow. As such, they were perfectly vertical! On a great sheet (A4 or A3), they will draw a circle for the Earth just as the first sketch of figure 2. They draw several sunrays (parallel, of course), and one following that vertical.

(You can begin to draw on a great sheet of paper the parallel sunrays and then cut in a coloured sheet a circle for the Earth, put it on the sheet and pierce it with something to fasten it on its center, and make it turn until the sunrays fall vertically on Syrene).

How do you place Alexandria now? Ask them what Eratosthenes measure this same day, at the same time? "The angle between the sunrays and the obelisk... so the angles these rays make with the vertical !" They will need to recover the value of this angle (7.2 degrees), and draw a schema, just as explained in fig. 2. The pupils will use tracing paper, on which they will draw the angle for Alexandria and they will make it slide on their figures until the ray on the obelisk becomes parallel to the others.

Fig. 2
(théorique)

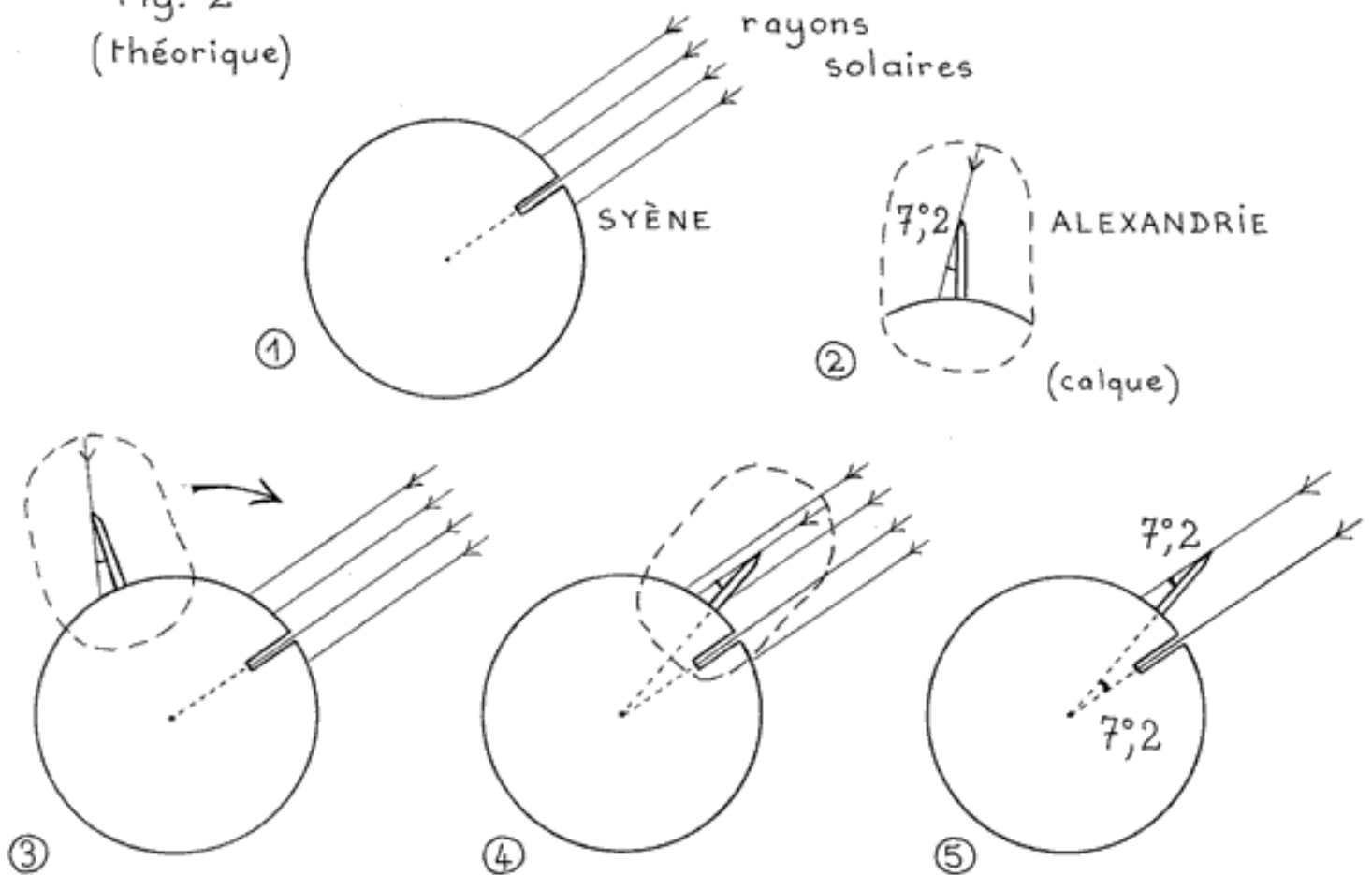

Eratosthenes secret :

When they have written down with a black pen the position of Alexandria, they draw the vertical going through this city that goes to the centre of the Earth. Ask them what is the angle between this vertical and the one of Syrene? "It looks strangely equal to the angular sector, the one measured by Eratosthenes".

To check that, they return the tracing paper and superimpose the angle to the one at the centre of the Earth. It works! This would be Eratosthenes' secret ! Make them check for another angle (twice that value, for example), and they get the same result. They create a new Alexandria at an angle of 14 degrees, draw the vertical and measure the new angle at the centre of the Earth. They can also use the protractor to check these hypothesis.

Then, they reproduce on their notebooks the figure without its irrelevant lines, proud to have discovered that by themselves. They will also note the conclusion : the famous secret discovered by Eratosthenes : the angle measured between the sunrays and the vertical in Alexandria is exactly the angle between Alexandria and Syrene at the centre of the Earth. They will then see the "Z of Zorro" that will surely help them remember this incredible result!

One more question : what would happen if the Earth was turned so as to make sunrays no more vertical in Syrene? (turn the circle of Earth slightly counter-clockwise).

They try the experiment, draw the angles, compare them, and see that the angles are not equal anymore !!! A new angle has appeared in Syrene, changing everything.

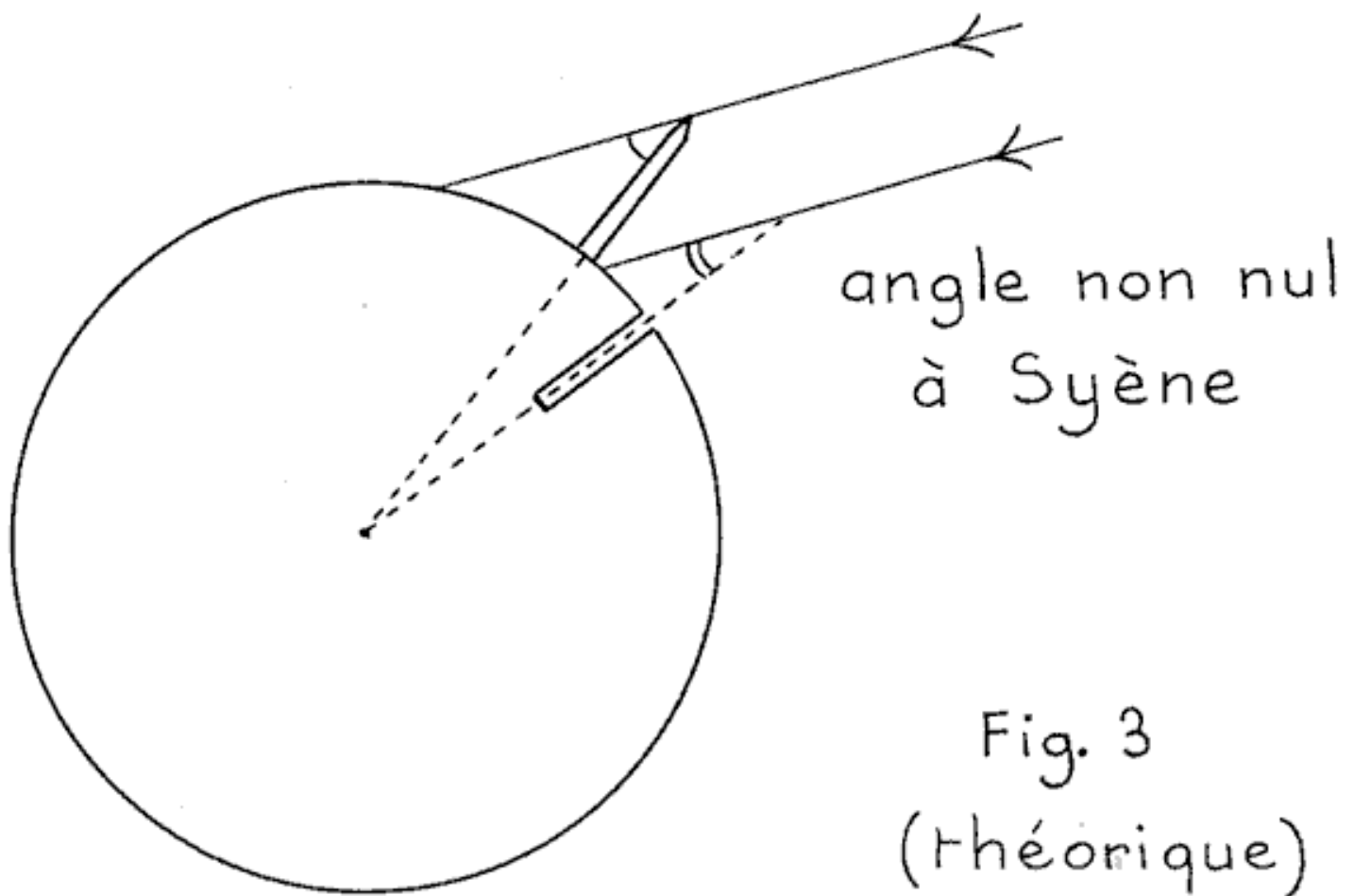

Tracing the new angles appeared in Syrene and Alexandria between the rays and the vertical, maybe they will discover after a few tries that the angle between the two cities at the centre of the Earth (see the first model) is equal to the difference of the angles measured in the two cities between the sunrays and the vertical (they can also measure them with a protractor and look for the relationships between the three angles : in Syrene, in Alexandria and in the centre of the Earth between the two cities). It can also be easily seen with the tracing papers.

They just have extended the conclusion to the cases (the most current!) when sunrays do not fall vertically. They will write down this discovery on their notebook, because it will be useful to reproduce Aratosthenes' figure with their own measures. (Note that this conclusion also applies on the 21st of June between Syrene and Alexandria, but that one of the angles is null... The difference is then equal to the angle measured in Alexandria.)

Now, your pupils are ready to measure the circumference of the Earth in any case!

c- To measure the length of the meridian passing through Syrene and Alexandria

To make them understand the rule of three (or rules of proportions), a rule they will need absolutely to measure the meridian, tell them to think about the following scenario :

Imagine that Eratosthenes measured a different angle in Alexandria. Imagine that Syrene and Alexandria are in fact on an Earth similar to a pie cut for example in 8 equal pieces, the two cities being just as on figure 4. If you know the length of the rim of a piece of the pie, how could you find the length of the circumference of that pie?

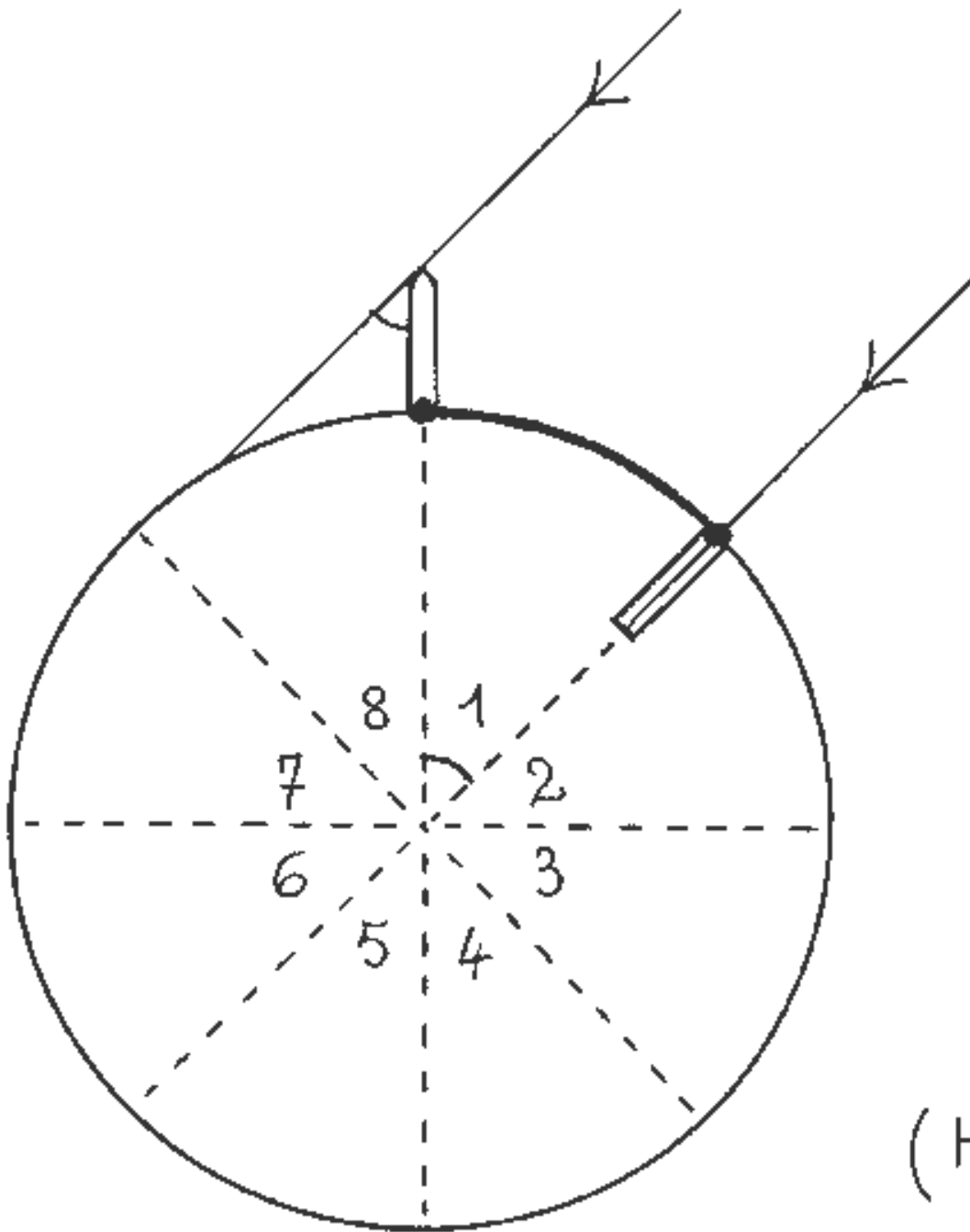

Fig. 4
(Théorique)

"It's easy, you only need to multiply the length by 8!" Are you sure? You can tell them to check : make a great circle, divide it in 8 equal sections and measure with two threads the length of the rim of a piece and the length of the entire circumference. They will find a difference of 8 to 1 between the

lengths of the two threads.

That's exactly what Eratosthenes told himself, but how many pieces are there in the "pie"?

They can suggest several experiments to try to discover it. You can divide the pupils in groups, in order to try all the proposals :

- they can use the angle of 7.2 degrees and make it turn around the centre of the Earth to see how many "pieces" they need to fill the Earth (or half the Earth, and then multiply the result by two).
- They can use a thread and compare the length of the rim for the "piece" Syrene-Alexandria (on the real figure made before) and compare it to the length of the circumference of the Earth.
- Those who prefer could divide 360 degrees (a whole circle) by 7.2 degrees (the angle at the centre).

They will find a factor of 50 precisely (through calculation, at least !).

They only need to use the rules of proportionality since Eratosthenes tells us that the distance between Syrene and Alexandria is of 5000 Egyptian stadiums. Multiply by 50 and find : 250 000 exactly !!! Just as the great Greek scientist. The puzzle is now solved.

But what was the Egyptian stadium distance value in the metric system? Final quest that will take them to encyclopedias or internet search engines. They will find the following answer :

1 Egyptian stadium = 157.5 meters, which gives a circumference of 39 375 km for the Earth : Compare it to the values found in your dictionaries and you will be astonished by the preciseness of this measure.

2- To use the surveys of another school to measure one's own meridian

Foreword : we suggest you, if you have time enough for that, to have a glance at the optional activities that could introduce notions of parallels and meridians on the surface of the globe, especially by comparing the measures of your angles with the ones published by the other schools. If you don't have time for that, you can decide to explain these notions in the classroom, with a globe and a planisphere (optional session : [To get one's bearings on the surface of the earth.](#))

a- To Choose your partner

Let's remind you in a few words the requirements for the success of this last step :

You must have measured the shadow of your gnomon at the time of solar midday (a 10 minutes delay can be accepted, but not more!) and deduced from that measure the specific value of the angle of sunrays with the vertical of your place.

You must have published your angle measure (s) in the table given on the site La main à la pâte (<http://www.mapmonde.org/eratos/measures.php?lang=en>), in order for the other classrooms to make use of your indispensable surveys

You must have chosen with the pupils a partner-school who made their measure at the same date on solar midday (a two-days difference can be possible, if you are close to June). This partner must have at least 3 or 4 degrees of difference in latitude with you. Note where the shadows point, because some schools see the Sun at its highest to the North on midday and so the shadow points to the South, unlike most classrooms on English territory.

b- Make your own " Eratosthenes' figure "

Now, you are going to make Eratosthenes' figure with your own city and that of the partner school chosen according to the data published in the table. The pupils make the schema of Figure 5 for a specific day, according to the same principle.

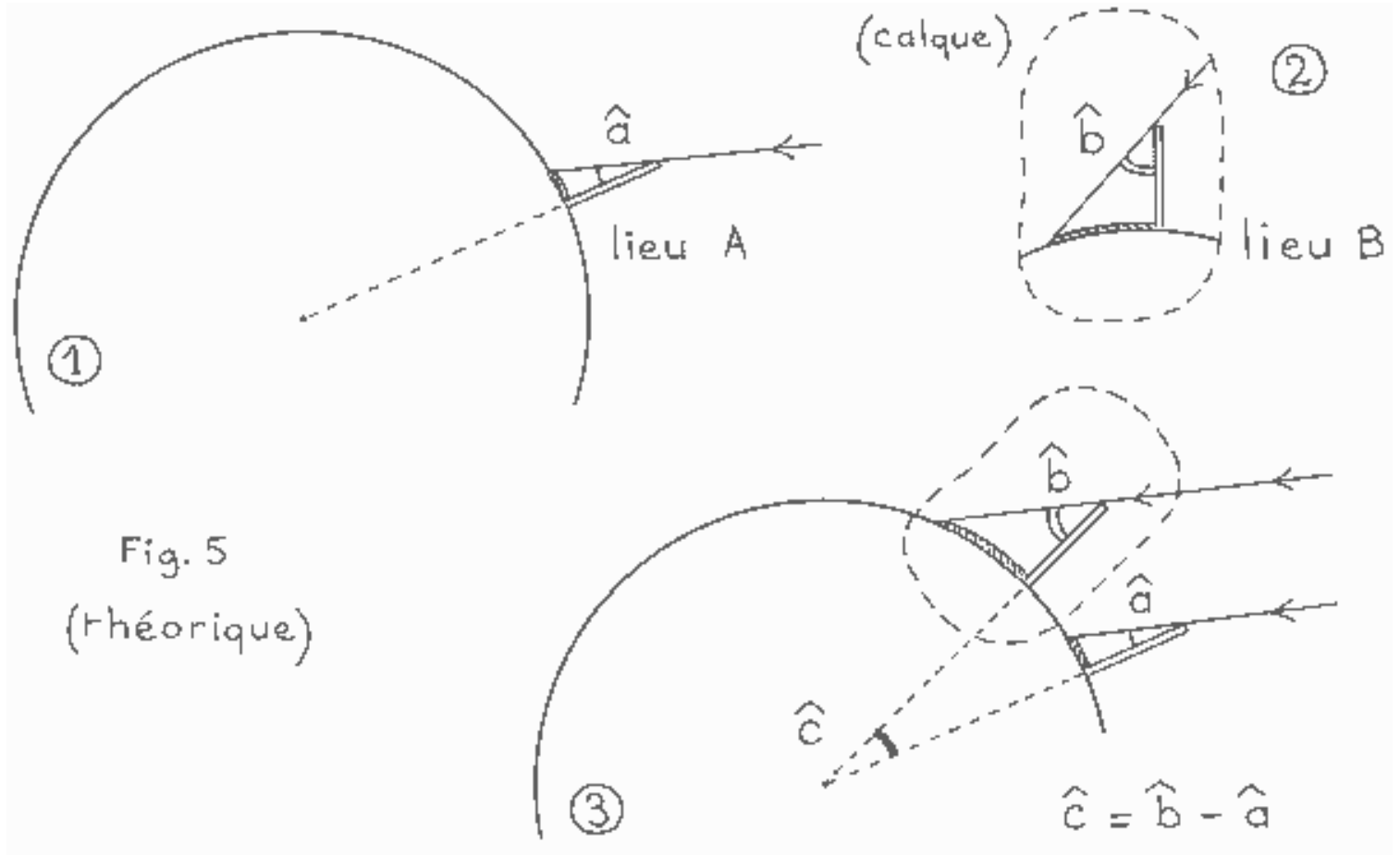

Tell them to make the tracing paper slide upon the section of the Earth. It is important for it to be made of a really great circle (or half-circle), because the two angles will be different by only a few degrees if both partners are in England.

Be careful! some schools in the intertropics belt or in the southern hemisphere will see the shadow point to the South, and the Sun will be at its highest to the North. If so, they will absolutely have to tell in the table in which direction the shadow was pointing, because it changes the calculation : use the last explanations given on Eratosthenes' figure and put a city in the southern hemisphere on the same meridian than Alexandria. The shadow being reversed, ask the pupils to draw the angle between the sunrays and the vertical for this city (or measure it) and the one between this city and Alexandria from the centre of the Earth. The idea is to find the relationship between these angles : you should, that time, add the values of the angles to discover the angle between the two cities at the centre of the Earth.

Fig. 6
(théorique)

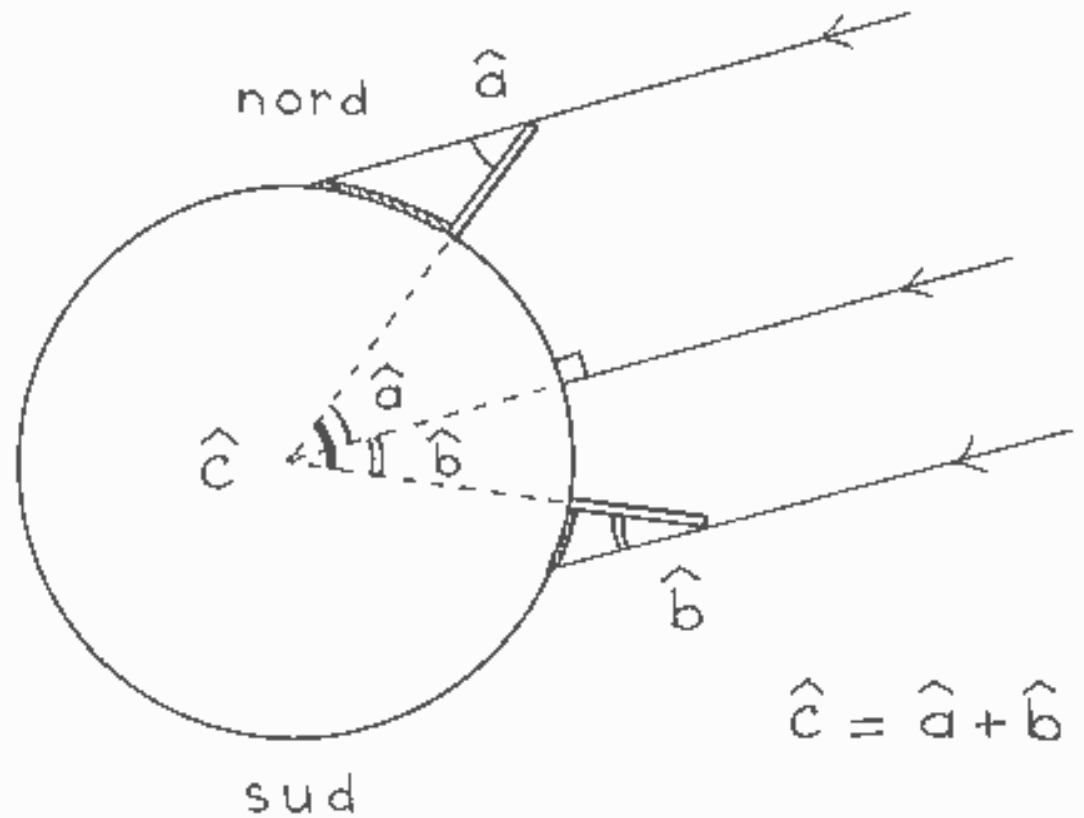

To be sure, you can draw the sunray that falls between these two cities and goes through the centre of the Earth : it has the role of Assouan, since the rays follow the vertical. It splits the angle at the centre of the Earth in two between the two cities. If you apply the principle of equality of angles discovered with the couple Alexandria and Assouan on these two "sub-angles", you find that the first angle (superior) is equal to the one measured in the northern city and the second to the angle measured in the southern city. You should add these two "sub-angles" to find the whole angle.

In a few words : if the shadows of the partner schools point to the same direction, (both to the north or to the south), you must subtract the angles measured between the sunrays and the verticals to get the angle at the centre of the earth. If the shadows point to opposite directions, you must add them.

c- To measure the distance between the partner cities

Just as in the case of Eratosthenes we talked about before, you only need to apply the rule of proportions to find the length of the circle of the Earth, with the distance between the two cities. You must know the distance between the two cities. Eratosthenes had opted for two cities on the same meridian (more or less), but in your case, your partner will probably not be on your meridian (on the same longitude). the pupils will have to admit this time that they should measure the distance between the parallels of the partner cities and not the direct distance between the two cities.

(To be convinced, ask yourself what imaginary city on your meridian will measure the same angle as your partner : it is the city placed on the same parallel. The difference? It will see the Sun at its own midday -at your hour-, and you have the right to place it on your drawing since we remind you that it is a section of the Earth along a meridian : your meridian.

Get a road map or an atlas to decide, from their scale, the distance between the two parallels. The maps of the atlas and some IGN maps show some parallels and meridians, they will be very useful. Be careful because of the

projection : on the planispheres, they distort the continents and do not respect the scales for each zone of the globe !

d - To measure the length of your meridian

You have now all the elements to make your calculation, you only need to find the multiplying factor that will make you pass from the distance between the parallels to the total circumference of the meridian. You can, if you wish, use the methods devised in part 1 to discover Eratosthenes' results or make a simple rule of three (or proportion rule) if your children have understood the principle of that method.

e - To find the diameter of the Earth.

Nothing easier : you have measured the circumference of our planet, you only need to divide by the famous Pi to find the diameter of our Earth, and you are done !

In his time, Eratosthenes had found 250 000 stadiums exactly for the circumference. This round figure shows that he did not want to be precise, but to get an idea of the Earth's size. And it was really successful, since it gives a result of a little more than 39 000 km and therefore a diameter of approximately 12 500 km.

The children will be able to compare their results to those of Eratosthenes and seek in dictionaries or on Internet the values recently found by the scientists (you will discover that Earth is not perfectly round like a ball, but that it is flattened on the poles and that its polar diameter is slightly less than its diameter at the Equator. They will also be able to communicate with their partner school through e-mail to discuss with their comrades of their results and their clever calculations.

You can try it again as many times you have synchronous measures with other schools. If no measure has been published for the same date of your own, you could use measures made on the day before or after (between May and June) because the angle you have measured doesn't change much from one day to the other.

If here are great differences exist between your result and reality, try to find with your pupils the possible origin of the error :

Inaccurate angle measure, measure of the distance between the partners inaccurate, etc. Publish your results on our site and discuss with your partners and with ourselves via Internet.

f- To publish your measures in the great results table

The measures table made for your school in the workspace Eratosthenes (<http://www.mapmonde.org/eratos/measures.php?lang=en>) now has a column for the measure of the meridian (in km). You only need to write down the result of your calculation in that column to make it appear in the measures table and show it to the other classrooms of the project. You can get to the workspace's user's guide (<http://www.mapmonde.org/eratos/help.php?lang=en>) to get more details on the methods of publication.

g- To send a postcard to all the members via our site

Like Emmanuel di Folco during his trip in Egypt, the classrooms can send one or more electronic postcards in memory of the project. Once printed, these cards can be cut and stuck in order to get a real postcard. This activity gives your pupils an opportunity to leave a trail of their journey in the footsteps of Eratosthenes and tell the other classrooms the great steps of their discoveries.

User's guide :

The postcard is made of four elements you will have to prepare before connecting to the site :

A text (a maximum of 10 lines and 100 words)

An image (jpg or gif, a maximum of 450 pixels wide and 400 pixels high)

A date : day/ month/ year

A legend (a maximum of 7 words)

Once these documents are ready, get to the workspace Eratosthenes.

Three options are open to you :

Add a postcard

Read or change the postcards

User's guide

The first option gives an access to the form made for you to publish your postcard. Copy the text, the date and the legend in the good windows and select the image on your computer. You only need to click "send" to save your work and make it visible to everyone! The name of your classroom will appear automatically in the signature of the postcard.

To see the result of your work, use the second option. The postcards your classrooms have made appear with a link "delete" and "modify". These links can only be read with someone with your password and your login. Be careful : you can change only the text of the postcard. If you wish to change the image, you have to delete the postcard and add a new one.

Advice :

On screen, the postcard is divided in two parts, one for the text, the other for the image and the legend. Tell your pupils to illustrate their postcard with a picture of the classroom and the gnomon, or pictures of the classroom in specific activities that pleased them.

Precautions :

Any publication on the Internet is under the laws of publications. Its author, editor and distributor are responsible for it. You must have a written authorization of the parents if you want to publish photographs where their children could be recognized. We therefore ask you to take the necessary precautions with the parents of children on your photographs or avoid photographs where the children can be easy to identify.

3- Last survey on the 21st of June

The 21st of June is a very special day since it is the one where Eratosthenes made his first measure. Furthermore, we know that in that summer solstice day in the northern hemisphere, the Sun gets exactly to the zenith in Assouan at solar midday, Assouan being on the Cancer Tropic. Like Eratosthenes, we encourage you to put an end to this project with a measure on the 21st of June (if the Sun wants!). Numerous fairs happen on that day, it is an opportunity to make a stall "Direct measure of the size of the Earth"!

You have probably seen that these days, during your surveys, the angle changes less and less from one day to the other as we get closer to the solstice. In the week around it, this variation will be negligible, so any measure made between the 17th of June and the 25th of June will be valid! So as not to be very disappointed if the day of the solstice the Sun does not show, make a survey as soon as you get to the 18th (and up to the 25th if necessary).

This will give the opportunity for all the classrooms to take some part to this historical measure !

You will then be sure to get a first-rate partner since the angle of the sunrays with the vertical to Assouan is null on that day. Our Egyptian partners in Alexandria and Assouan promised us to join the party and make a simultaneous measure. It is the opportunity to make this historical survey with your pupils. You will only need to measure the distance between your city and the parallel on which Assouan is placed, so your distance to the Cancer Tropic. Furthermore, your angular difference with the tropic (the angle you measure this day) is high enough for you to have a precise measure that will easily give you a good measure of the diameter of the Earth. Try this great experiment on the 21st of June !

Optional session (Sequence 5)

To get one's bearings on the surface of the Earth

New step on Eratosthenes' course : once your first "serious" and accurate measures have been made, you will be able to compare your results with those of the partner schools. Before that, you'll have to get yourself familiar with geographical coordinates that will help you localize the other schools on the territory.

Duration : 2 sessions

Notions tackled : cartography, latitude and longitude, time zones.



Equipment :

For the class :

- A map of France on the wall
- A road map of your region
- An A3 sheet
- A transparent plastic sheet

For each group of 4 pupils :

- A map of your territory (country, island) on an A4 sheet
- A cross-ruled A4 sheet.
- A spherical object (globe, tennis ball, orange,...)
- An angular sector

Introduction

You can begin this session with a reminder of the principle of the operation. Nearly 150 classrooms (<http://www.mapmonde.org/eratos/schools.php?lang=en>), in 17 different countries are making the same measures you are making. With several angle measures and the distance between each of your partners, you are soon, like Eratosthenes, find the diameter of the Earth. This list of names are for the most part

unknown to you, so you are going to find where your partners are.

Summary of the sequence:

1) Repérage dans le plan : votre voisinage

2) Espace courbe : du local au global

1) Locate yourself : your surroundings

Whole classroom

To get your pupils familiar with the notions of locating oneself, begin with the towns, cities, summits or monuments next to the school, places they know. Make a list and tell them to make a map of your surroundings (you could use a road map as a help, for example).

Put your school in the middle of an A3 sheet and tell them to put on this new map the elements of the list they have made. How can they draw a map as exact as possible?

Decide of a scale with them, ask them what it would be necessary to know about each place to put it on the map? What is the simplest and fastest way to put all these places on the new map?

They could give you two major strategies :

- 👁 For some of them, the distance between the points and the school will be a first step. They will then try to find their direction on the map
- 👁 Maybe some others will want to make a squaring and simply put the places just as pawns on a chessboard.

In groups of 4-5 pupils

You will then be able to divide your classroom in groups, each group trying his strategy.

👁 First strategy :

As they do not know all the distances, even if they have an idea of them because of their daily movements, you will use a local road map to help you and calculate with the scale the distances on your own sheet. It is not enough : you also need to know in which direction is the place. They will be able to use the 4 cardinal points, at first. Is a village to the north or the south is a first step. But how can they be more precise? Maybe some of them will remember the experiments with the angular sectors. They will cut a sector, one side of which will be the direction and the other the line that joins your school to one of the sites. With the road map, the pupils can now cut as many angular sectors as there are places on the list, choosing as reference one of the cardinal points (that could be different for each place if necessary). They will write down on each side of the sector the name of the site, its distance from your school and the direction chosen as reference. They will only need then to use these sectors on the sheet.

👁 Second strategy :

They will also need to decide two coordinates : not the distance and the direction, but two distances : one "horizontal" and the other "vertical", for the number of squares in both directions of their squaring. They will have to make two squarings : one on the road map and the other on their sheet with a scaling. They will then be able to put the places chosen on their sheet, more or less precisely, depending upon the size of their squaring.

You can then reproduce, at your chosen scale, the surroundings of your school and even orientate this new map in your classroom with a compass!

Choice of the best method :

Ask them which is the best method for these maps, from the point of view of easiness and fastness. Let them talk about it. Ask them now to put themselves in their thoughts in one of the places they have put on your map (except your school). Tell one of them to explain to one of his comrades which way he should take on the map (and with his method) to go from that point to another place. Which is the best map now to find that way?

With the first strategy, they have to get through the process all over again : measure the distance between the two places and the direction . With the second strategy, they only need to give the number of squares to make horizontally and vertically, it is really much easier! They will soon be convinced of the efficiency of that coordinates system, called "Cartesian" (the others are called "polar").

The country scale :

Put on the blackboard a wall map of your country or island and get a transparent plastic sheet (a cover for books, for example, or flower paper,...) of the same size. Give each group an A4 sheet on which is drawn the outline of the territory.

Put the four cardinal points on the maps

With the wall map, make a list of the most well-known cities and put a coloured sticker on your own town or village.

Tell them to find an easy way to locate these cities on the map. How can they define their position?

They will certainly choose the squaring method, and you will be able to use the game of naval battle as a way to learn (that is not so usual !!!). Each square will be located with a letter and a figure.

So, in the first time, you will draw a squaring you will superimpose to the wall map in order to locate the place of the major cities or mountains. They will wonder about the size of the squaring. They will decide for themselves the necessary parameters, and then make the squaring on the group sheet in order to put the points on the map as accurately as possible.

How many squares high? Wide? What size for a square?

Will they be square or rectangular? Which numbers will they use? In which way? What will be the point of origin? How can they make the two squarings coincide? Let them discuss along the problems met, the groups having opted for the first method will be at an advantage and will be able to help the others in their choice.

Notes : How do the lines cross each other in the squaring? In which directions?

2-Curved space : from the local to the global

In groups

During this second part, you are going to try to get progressively to the creation of a net of meridians and parallels that define the geographical coordinates used to locate oneself on the Earth.

How could you apply now to the globe what they have just used? Give them copies of the squaring you have prepared, and spherical objects : tennis ball, oranges,...

Tell them to apply the squaring upon the spheres. What is wrong?

How could they design a squaring adapted to this new geometry? Which shape take the lines of the plane squaring when they get rolled upon a ball?

Towards a new reference.

Each group is going to roll the cross-ruled paper around a sphere. First, they will make a cylinder, and they will see that the lines which were parallel become circles. To apply the whole squaring to the sphere, they'll have to fold the cylinder at the top and the bottom, like a sweet. They see then that the vertical lines are closing and all go towards to diametrically opposed points

As it is impossible to apply perfectly the surface of the sheet upon the sphere, they take another sphere upon which they are going to train to draw this strange network of lines, creating a brand new squaring they will try to make as regular as possible.

The network closes upon itself on the sphere. All the lines on the paper become circles, of various diameters, and parallel for the horizontal lines, cutting themselves on two points for the vertical lines. You can interpret with them this new drawing, and cut one of the spheres for example (very easy if you use fruits : an orange is perfect for that). You will cut in quarters for the circles with the same diameter, and in discs for the parallel ones.

Finally, you will give a number to the slices just as for the plane squaring, and they can now make a world-scale naval battle ! If the lack of Sun delayed you in the sequences, you can show them the network used for the Earth with a globe. The two points of convergence of the vertical lines are the north and south poles. Note that the squares on the globe are numbered by a scale in degrees (just like a protractor). Take care to make them see the new origins : the zero of the vertical scale on the equator and the one on the horizontal scale : a line called "Greenwich meridian, that goes through France near Paris.

You can explain the vocabulary linked to that new squaring as soon as these notions are clear enough for them : meridian, parallel, equator, longitude, latitude. In order to get more familiar with them, tell them to locate your school on a map, as well as your partner schools, with the latitude and longitude given in the table on the site La main a la pâte (new link : <http://www.mapmonde.org/eratos/schools.php?lang=en>). This exercise applied to your country can be used in an infinite number of ways, it depends upon what you want and the time you have. For once, you don't need any sun for it !



You are now ready to get to compare your measures with the ones of your partners and at last measure the diameter of the Earth. If you have more time, you can go further into these notions of latitude / longitude and think with your pupils about the idea of hour all around our planet.

Project

Post-test : questionnaire for the pupils

Preliminaries

Eratosthenes comes to its end... We hope that your pupils fully enjoyed all these exciting activities that led them to "measure the Earth", with the shadow of a simple vertical staff!

In order to assess the knowledge they have acquired with regard to the first test, this is a post-test using the contents of the pre-test, with two other questions, one about the famous figure discovered by Eratosthenes, and the other about geographical co-ordinates.

Mode

Time : According to the training of your pupils, one 45 minutes session, or two 30 minutes sessions (but the slowest pupils should be able to finish the test after).



Equipment :

For each pupil :

The test forms and a few blank sheets for the drawings ;
pencil, rubber, coloured pencil or felt pen.

PROJECT : “ FOLLOWING IN THE STEPS OF ERATOSTHENES ”

17 questions to take bearings on what you know about a few things

Before you answer a question, read it from the beginning to the end. .

When you have to select an answer, surround the chosen answer in black.

*When you should answer by a **drawing**, draw it on another sheet, on which you will write down the **number** of the question.*

1 – Under the shadow !

Have you already watched the shadows? Draw the shadow of a stick lit by the sun (the stick is stuck in the ground).

Then, do the same for three sticks well away from the others.

2 – Is the black board askew?

Vertical, horizontal : make a drawing that illustrates these two words. Draw a line for the ground ; then, draw a vertical object as if it was laid upon it, and then another one, horizontal.

Can you name (and draw?) two tools that could check :

- the verticality of the first object : _____

- the horizontality of the second object : _____

3 – At the angle of my street

Maybe you already know what an angle is, and maybe also a right angle? In the angles below, surround those you think are right angles.

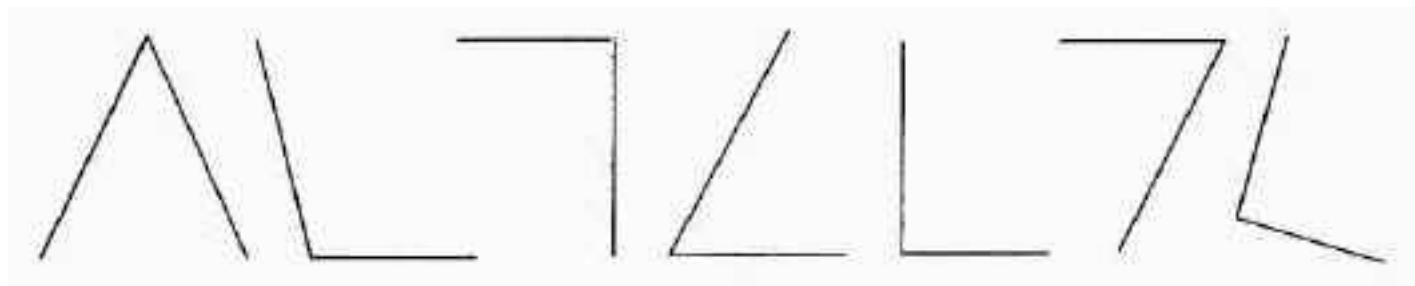

Do you know the name of an angle less "open" than the right angle?

It is an _____ angle

Do you know the tool used to measure an angle?

It is a _____

4 – Let's take a street parallel to your street...

Have you already heard about "parallel lines"? Even if you have not, maybe you can find what a parallel line is in these "groups" of lines :

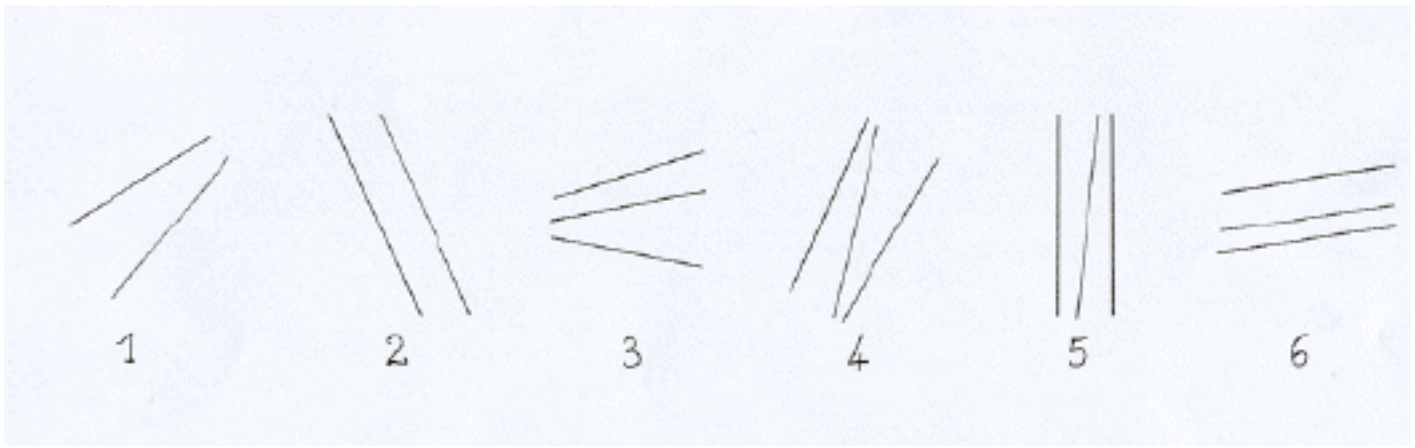

If you think you have found, surround the "groups" of parallel lines on the drawing

5 – Z like Zorro

Watch the three steps necessary to construct this funny “Z” :

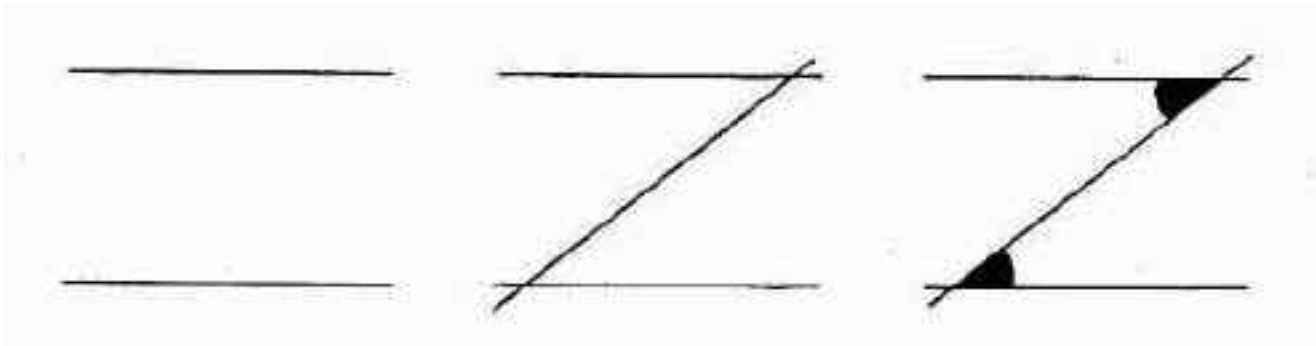

The two angles in black

are special : how ? _____

It could be checked, how ? _____

6 – Hello Earth !

How the Earth is shaped? (draw it on a sheet of paper)

How do you know it ? _____

To what kind of object does it make you think?

7 – Other sticks !

Use the drawing of Earth you've just made and add, on the rim, three small sticks stuck on the ground like stakes, but very far away from the others.

8 – The Earth is under the Sun

Draw the Earth as you imagine it from space, with continents for example, but also lit by the Sun. If you want to show that it is night somewhere on the planet, fill this part in black.

9 – Night and day !

Among these four sentences, surround the one (or ones) that explain why there is a night and a day on Earth (you can use more than one answer) :

- 1) The Earth turns around the Sun
- 2) The Sun turns around the Earth
- 3) The Earth spins upon herself
- 4) The Earth spins upon herself and turns around the Sun.

10 – West wind

This is a map of France with a compass card that give you the four cardinal points :

the north (N) the south (S) the east (E) the west (W)



Write down the initial of each cardinal point well on its place at the tip of a point of the compass card. On the map, you can see where is Paris : take a place to the north of it a write north, a place to the south of it and write south, etc.

11 – Travel through the world

This a map showing the five continents : it is a planisphere. Write the four cardinal points in the four small rectangles. Find the United Kingdom, the United States, China, and Lapland, and colour them with a different colour for each.

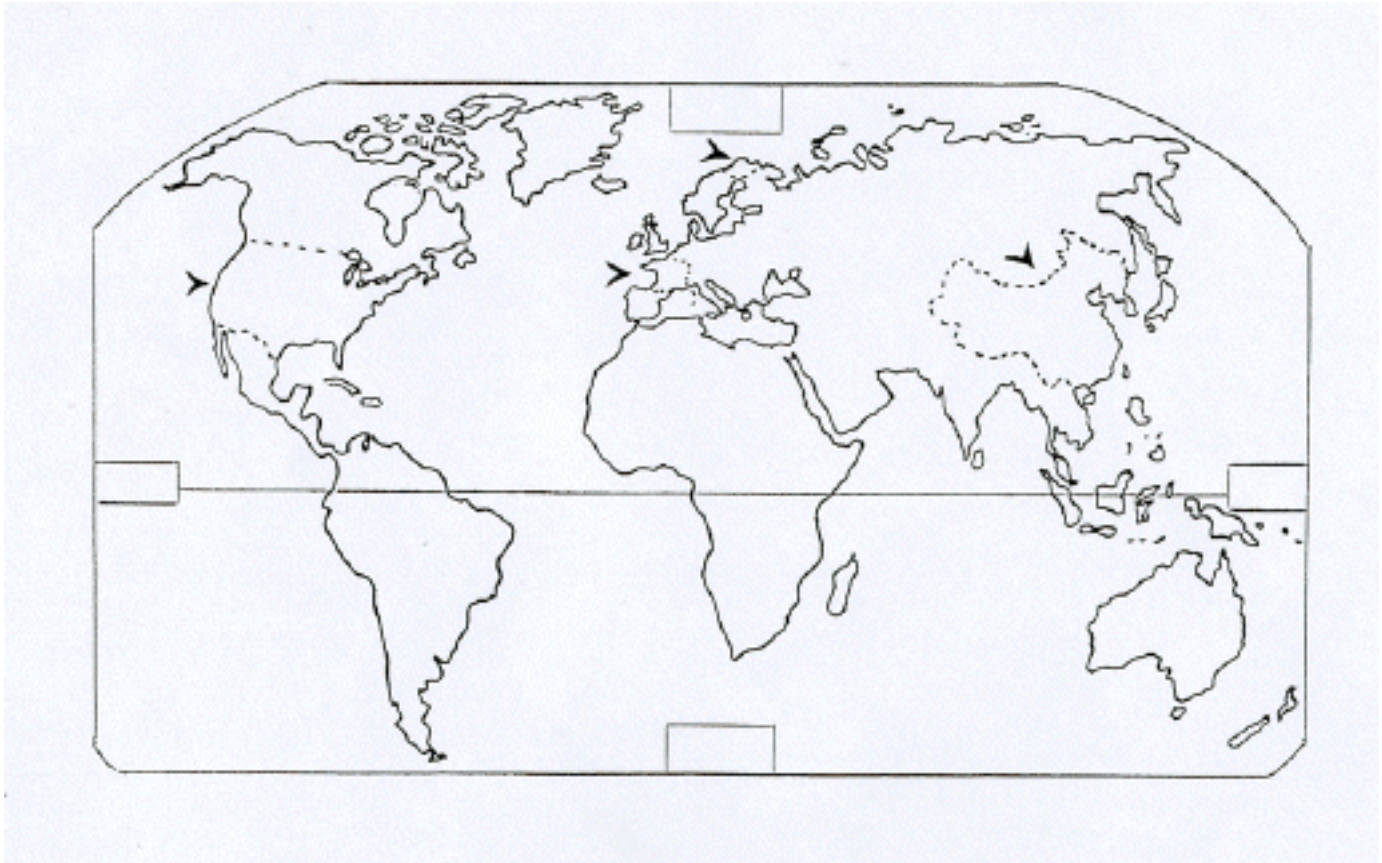

Do you think the United States are :

- to the west of the United Kingdom

- to the east of the United Kingdom

Do you think France is :

- to the west of China

- to the east of China

12 –Is it time to get up or to go to bed?

If it is nighttime in some countries and daytime in others, it means that time is not the same all around Earth. When English pupils get up in the morning, other pupils in the world are going to bed :

Can you tell who they are ?

Young Americans are going to bed?

Young Chinese are going to bed?

Young Eskimo from Lapland (north of Europe) are going to bed?

13 – And the Sun!

Do you know where you can see the Sun raise?

to the north to the south to the east to the west

Do you know where you can see the Sun set ?

to the north to the south to the east to the west

14 – Face the Sun !

Now, imagine you face the sea (or a plain), with the Sun in front of you, high in the sky. When, in the day, can you see it like that? _____

In which direction can it be at that moment? _____

Draw a line for the horizon, then, in the middle and high, the Sun in the sky.

Draw the course of the Sun from the morning when it rises, to the night when it sets. According to your answers to questions 13 and 14, try to place the four cardinal points. Finally, draw some arrows on the course of the Sun.

15 – With the passing days, nights and seasons

Do you know why, in France, night is longer in winter than in summer? _____

Do you know why it is cold in winter and hot in summer ? _____

16 - Eratosthenes' great idea

Will you be able to complete the famous figure discovered by Eratosthenes? Add two sunrays to this schema : one of them getting to the bottom of the well, the other on the obelisk, to the ground (and even slightly beyond, with a dotted line). Then, to the centre of the Earth, draw the vertical of Syrene and the one of Alexandria. Finally, color the two equal angles (with the Z of Zorro) with which Eratosthenes measured the meridian.

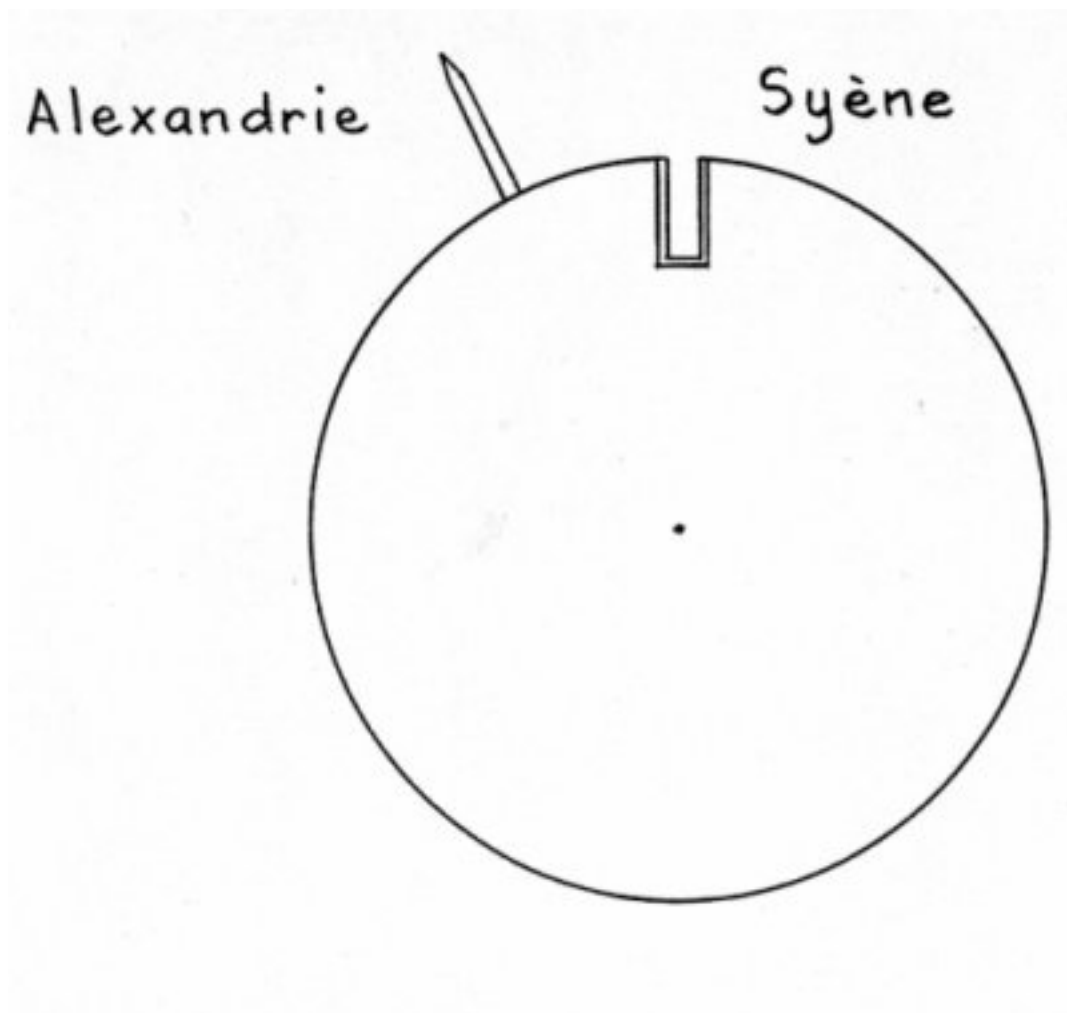

17 - Meridians et parallels

This is another schema of the globe, with two cities, A and B. Draw the meridian and then the parallel going through the city of A. Do the same for the city of B. Show, with a dotted line, the distance that should be taken -in Eratosthenes' operation- to calculate the length of the meridian.

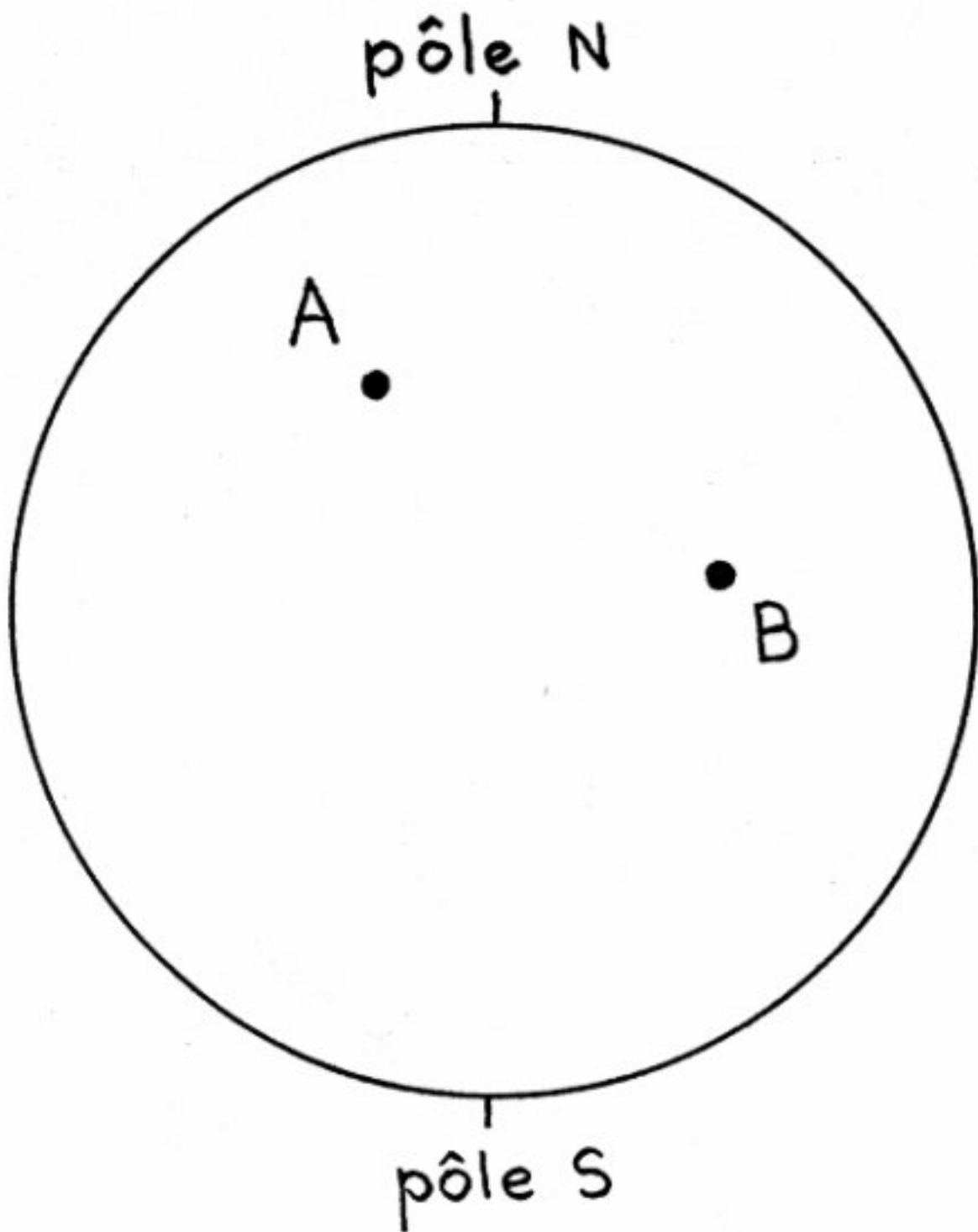

We wish you a happy end of school year, happy holidays, and see you on the site in next September for brand new scientific adventures with La main à la pâte.
